

Strategy-Proof Social Choice on Single-Peaked Domains:

Possibility, Impossibility and the Space Between *

KLAUS NEHRING

Department of Economics, University of California at Davis
Davis, CA 95616, U.S.A.
kdnehring@ucdavis.edu

and

CLEMENS PUPPE

Department of Economics, University of Bonn
Adenauerallee 24 – 42, D – 53113 Bonn, Germany
clemens.puppe@wiwi.uni-bonn.de

March 2002

*This research started when one of us attended Salvador Barberá's lucid survey talk on strategy-proof social choice at the SCW conference 2000 in Alicante. Our intellectual debt to his work is apparent throughout. This paper combines material from two earlier working papers that circulated under the titles "Strategy-Proof Social Choice on Single-Peaked Domains. Part I: Strong Possibility Results on Median Spaces" and "Strategy-Proof Social Choice on Single-Peaked Domains. Part II: The Impossibility-Possibility Frontier." For helpful comments we are grateful to Hervé Moulin and participants of seminars at Rice University, Southern Methodist University, UC Davis and the Universities of Karlsruhe, Mannheim and Bonn.

Abstract *We define a general notion of single-peaked preferences based on abstract betweenness relations. Special cases are the classical examples of single-peaked preferences on a line, the separable preferences on the hypercube, the “multi-dimensionally single-peaked” preferences on the product of lines, but also the unrestricted preference domain. Generalizing and unifying the existing literature, we show that a social choice function is strategy-proof on a single-peaked domain if and only if it takes the form of “voting by committees” satisfying a simple condition called the “Intersection Property.”*

We then classify all single-peaked domains in terms of the extent to which they enable well-behaved strategy-proof social choice. In particular, we show that a single-peaked domain admits a non-dictatorial and neutral strategy-proof social choice function if and only if the associated betweenness relation has the property that for any triple of social alternatives there exists a median, i.e. an alternative that is between any pair of the triple. Generalizing the Gibbard-Satterthwaite Theorem, we also characterize the domains that admit only dictatorial strategy-proof social choice functions. Finally, we characterize the single-peaked domains that enable strategy-proof social choice with anonymity and with no veto power, respectively.

1 Introduction

In view of the celebrated Gibbard-Satterthwaite Impossibility Theorem, non-degenerate social choice functions can be strategy-proof only on restricted domains, that is: only when some a priori information on the possible preferences over social states is available. Two types of preference restrictions in particular have been shown to give rise to possibility results. On the one hand, in economic contexts it is assumed that individuals care only about certain aspects of social alternatives, for instance about public and own private consumption but not about the distribution of the other individuals' private consumption. If, in addition, utility in private wealth is quasi-linear, the well-known class of Groves mechanisms offers a rich array of strategy-proof social choice functions.

By contrast, in “pure” social choice (“voting”) contexts individuals care about all aspects of the social state. Here, the assumption of *single-peaked* preferences is natural and frequently ensures possibility results. The most basic example is that of social states ordered as in a line, representing, for instance, policy choices that can be described in terms of a left-to-right scale. Single-peakedness in this context means that individuals always prefer social states that are *between* a given state and their most preferred state, the “peak” (see, e.g., Moulin (1980)). Another strategy-proofness enabling domain arises if the social choice concerns an independent set of yes-or-no issues, such as which among a set of proposed bills to endorse. Here, one needs to assume that individual preferences are ordinally separable in issues, i.e. that the preference over some issues is not affected by what choice is made on other issues (see Barberá, Sonnenschein and Zhou (1991)). By introducing an appropriate notion of betweenness, separability can be interpreted as another instance of single-peakedness. Combining these two examples, single-peakedness relative to an appropriate betweenness relation has also been shown to enable strategy-proofness on a Cartesian product of lines (see Barberá, Gul and Stacchetti (1993)).¹

The goal of the present paper is to explore the possibility of strategy-proof social choice for domains of single-peaked preferences based on *general betweenness relations*. Following Nehring (1999), a natural way to conceptualize betweenness is in terms of the differential possession of *relevant properties*: a social state y is between the social states x and z if y shares all relevant properties common to x and z . Single-peakedness means that a state y is preferred to a state z whenever y is between z and the peak x^* , i.e. whenever y shares all properties with the peak x^* that z shares with it (and possibly others as well). As further illustrated below, many domains of preferences that arise naturally in applications can be described as single-peaked domains with respect to such a betweenness relation. For instance, the standard betweenness relation in case of a line is derived from properties of the form “to the right (resp. left) of any given state.” In fact, to our knowledge *all* domains that have been shown to enable strategy-proof social choice in a voting context are single-peaked domains. But there are also single-peaked domains that give rise to impossibility results. For instance, the unrestricted domain envisaged by the Gibbard-Satterthwaite Theorem can be described as the set of all single-peaked preferences with respect to a vacuous betweenness relation that declares no social state between any two other states; the corresponding relevant properties are, for any social state x , “being equal to x ,” and “being different from x .”

¹Related domain restrictions have been considered, among others, by Border and Jordan (1983) and Le Breton and Sen (1999).

The Structure of Strategy-Proof Social Choice

The interpretation of betweenness in terms of properties lends useful mathematical structure to the analysis, but not quite enough. Throughout, we shall rely on the assumption that a property is relevant if and only if its negation is relevant (“closedness under negation”). This assumption allows us to invoke, and thereby to generalize, a fundamental insight of the previous literature, namely that strategy-proof social choice functions on single-peaked domains have the structure of “voting by committees” (see Barberá, Sonnenschein and Zhou (1991), Barberá, Massò and Neme (1997)). This structure has two aspects: First, social choice depends on individuals’ preferences through their most preferred alternative only. Second, the social choice is determined by a separate “vote” on each property: an individual is construed as voting for a property over its negation if her top-ranked alternative has the property. In the special case in which voting by committees is anonymous and neutral, it takes the form of “majority voting on properties,” that is, a chosen state has a particular property if and only if the majority of top-ranked alternatives have that property.

Crucially, this fundamental insight describes only a presupposition for strategy-proofness, not a possibility result. For without restrictions on the family of properties deemed relevant and/or the structure of committees, the properties chosen by the various committees may well be mutually incompatible. Consider, for example, majority voting on properties on a domain of three states x , y and z , and take as relevant the (six) properties of being equal to or different from any particular state, corresponding to the unrestricted domain of preferences. If there are three agents with distinct peaks, a majority of agents votes for each property of the form “is different from state w .” Since no social state is different from *all* social states (including itself), the social choice is therefore empty.

A committee structure is called *consistent* if the properties chosen by each committee are always jointly realizable (irrespective of voters’ preferences). We show that a committee structure is consistent if and only if it satisfies a simple condition, called the “Intersection Property.” This leads to a unifying characterization of strategy-proof social choice on abstract single-peaked domains, namely as voting by committees satisfying the Intersection Property.²

Strong Possibility on Median Spaces

The Intersection Property imposes restrictions on the committee structure that reflect the structure of the underlying space. It does not answer the question for which single-peaked domains *there exist* well-behaved strategy-proof social choice functions. This problem is the central concern of the present paper. While, as indicated above, the literature has come up with a number of examples of such domains, it has not posed the question in generality. First, we ask which betweenness relations (respectively, which restrictions on the class of relevant properties) ensure consistency of *any* (well-defined) committee structure. In this case, we shall say that voting by committees is *universally consistent*, thereby ensuring the existence of a maximal class of strategy-proof social

²In the context of subsets of the product of lines, Barberá, Massò and Neme (1997) already have provided a characterization of consistency in terms of a property they also called “intersection property.” Their condition is less transparent and workable than the one obtained here; for instance, in the anonymous case of “voting by quota,” our condition directly translates into a system of linear inequalities, representing appropriate bounds on the quotas (see Section 3.4 below for details).

choice functions. Our first main result in this context shows that voting by committees is universally consistent if and only if the betweenness relation has the property that, for any three distinct states, there exists a state between any pair of them. Such a state is called a *median* of the triple, and the resulting space a *median space*.³ A second result shows that the existence of a median for any triple of alternatives is also necessary and sufficient for the possibility of *neutral* and non-dictatorial strategy-proof social choice.

**The Gibbard-Satterthwaite Theorem Generalized:
A Characterization of Dictatorial Domains**

The strong possibility results on median spaces contrast sharply with the Gibbard-Satterthwaite impossibility result according to which the only strategy-proof social choice functions on an unrestricted preference domain (over at least three alternatives) are dictatorial. In Section 5, we derive a condition (“total blockedness”) that is both necessary and sufficient for a single-peaked domain to enable only dictatorial strategy-proof social choice. The unrestricted domain as well as many other single-peaked domains are totally blocked. To illustrate the scope of the analysis, consider the following figure.

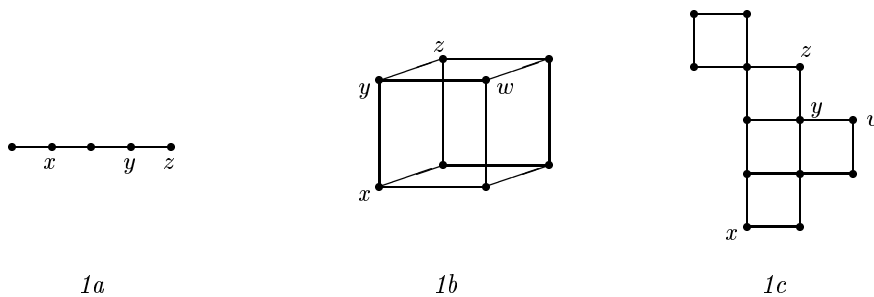

Strong Possibility on Median Spaces

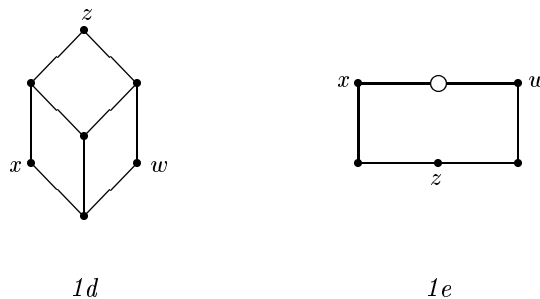

Partial Possibility on Quasi-Median Spaces

³A related but different approach emphasizing the role of medians is taken by Bogomolnaia (1999) who considers generalized “median rules” on sets of alternatives which are embedded into an Euclidean space. In contrast to our analysis, Bogomolnaia (1999) restricts attention to anonymous rules, and obtains characterizations only in special cases.

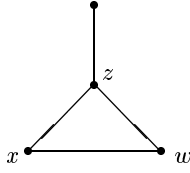

1f

Almost Impossibility

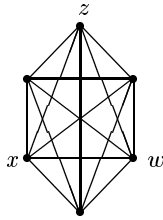

1g

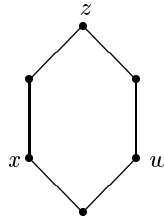

1h

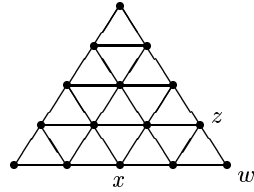

1i

Impossibility on Totally Blocked Spaces

Figure 1: Examples of single-peaked domains based on graphs

Each graph corresponds to a different set of social states represented by its nodes. The relevant betweenness relation is the natural one: a state/node is between two other states/nodes if it lies on some shortest path connecting them.⁴ Endowed with this notion of betweenness, the three graphs in the top row are all median spaces. Indeed, in Fig. 1a the betweenness relation is the standard one with the middle point y as the median of x , y and z . In Fig. 1b and 1c, y is the median of x , z and w .

By contrast, none of the remaining graphs in Fig. 1 is a median space: in each case the indicated triple x , z , w does not admit a median.⁵ In fact, as we will see, the three graphs in the bottom row of Figure 1 give rise to strong impossibility results in the sense that the associated single-peaked domains only admit dictatorial strategy-proof social choice functions. For the single-peaked domain associated with the graph in Fig. 1g this follows from the Gibbard-Satterthwaite Theorem: since every point is connected with any other point by an edge, no point is between two other points; but in this case any preference is (vacuously) single-peaked, i.e. the associated single-peaked domain is the unrestricted preference domain.

⁴A shortest path is one with a minimal number of edges; note that such paths are, in general, not unique.

⁵The interpretation of the blank circle in Fig. 1e is that the shortest path connecting x and w comprises two edges; at the same time, no social state is (strictly) between x and w .

Partial Possibility on Quasi-Median Spaces

Spaces that are not totally blocked need not be median spaces; examples are given in Fig. 1d, 1e and 1f. For instance, as a non-median space the graph in Fig. 1d does not admit majority voting by properties; nonetheless, it does admit “qualified majority voting on properties.” In this figure, the relevant properties are the three four-cycles and their complements. For example, the rule according to which the social choice belongs to any of the four-cycles if and only if at least one third of the voters’ peaks are in that four-cycle is well-defined (consistent) and strategy-proof; see Section 7 for a broad class of spaces generalizing this example.

By contrast, while Fig. 1f does admit non-dictatorial strategy-proof social choice functions, none of these is anonymous. Fig. 1e, on the other hand, admits anonymous social choice functions; all of these are fairly degenerate, however, in that at least one property *must* be chosen unanimously. This implies in particular that the condition of “no veto power,” which guarantees that a social state is chosen whenever it is the peak of all but one voters, can never be satisfied.

In the two final sections of this paper, we thus ask which spaces enable not merely non-dictatorial but anonymous and veto-free social choice under strategy-proofness.⁶ It turns out to be possible to characterize these spaces geometrically in terms of the notion of a “median point:” a state/node y is a *median point* if any triple containing y has a median. For instance, in Fig. 1d the median points are exactly the four non-labelled points (all points except x , z and w); similarly, the median points in Fig. 1e are the two points different from x , z and w . By contrast, in Fig. 1f there are no median points, since for any given alternative one can find two other alternatives such that the resulting triple has no median. A space with at least one median point will be referred to as a *quasi-median space*. In Section 6, we show that if a space has a median point then it admits an anonymous strategy-proof social choice function, and that this is almost necessary. In the final Section 7, we show that strategy-proof social choice functions with no veto power exist, roughly speaking, if and only if the set of median points is “connected” in an appropriate sense.⁷

The remainder of the paper is organized as follows. Section 2 introduces the central concept of betweenness relations based on families of relevant properties, the derived notion of convexity, and the definition of single-peakedness.

In Section 3, we use these concepts to provide a generalization and unification of the existing literature, including the main results of Moulin (1980), Barberá, Sonnenschein and Zhou (1991), Barberá, Gul and Stacchetti (1993), Barberá, Massò and Neme (1997) and Bogomolnaia (1999). Specifically, we show that any strategy-proof social choice function on the domain of all single-peaked preferences satisfying a weak condition of “voter sovereignty” must be voting by committees, i.e. in our framework: “voting by properties” (Theorem 1). We then derive a simple necessary and sufficient condition for the consistency of committee structures, the “Intersection Property.” We thus obtain a general characterization of strategy-proof social choice on abstract single-peaked domains, namely as voting by committees satisfying the Intersection Property (Theorem 2).

⁶As will be shown, spaces that allow for veto-free and strategy-proof social choice functions also allow for *anonymous* such functions; thus, there is no trade-off between the two criteria.

⁷While median spaces (that is: spaces in which all points are median points) are well-known in abstract convexity theory (see, e.g., van de Vel (1993)), spaces in which only some points are median points (“quasi-median spaces”) do not seem to have been considered before.

Section 4 introduces the notion of a median space. It is shown that voting by committees is universally consistent if and only if the underlying domain of social states is a median space (Theorem 3). Median spaces thus give rise to the possibility of strategy-proof social choice in the strong sense that *any* well-defined voting by committees rule is consistent. Moreover, we show that any neutral strategy-proof social choice function *must* be defined on a median space, provided it is to be non-dictatorial (Theorem 4).

In Section 5, we generalize the Gibbard-Satterthwaite Theorem by characterizing the class of all single-peaked domains that only admit dictatorial strategy-proof social choice functions (Theorem 5). Roughly, the characterizing condition (“total blockedness”) says that there are too many families of mutually incompatible properties.

In Section 6, we characterize the class of all single-peaked domains that admit anonymous and strategy-proof social choice functions (Theorem 6), and in Section 7 we provide the conditions on the domain under which such social choice functions can satisfy “no veto power” (Theorem 7). Section 8 concludes, and all proofs are collected in an appendix.

2 Single-Peaked Preferences Based on General Betweenness Relations

2.1 Betweenness

Let X be a finite universe of social states or social alternatives. It is assumed that the elements of X are distinguished by different *basic properties*. Formally, these properties are described by a non-empty family $\mathcal{H} \subseteq 2^X$ of subsets of X where each $H \in \mathcal{H}$ corresponds to a property possessed by all alternatives in $H \subseteq X$ but by no alternative in the complement $H^c := X \setminus H$. The basic properties are thus identified *extensionally*: for instance, the basic property “the tax rate on labour income is 10% or less” is identified with the *set* of all social states in which the tax rate satisfies the required condition.

Throughout, we assume that \mathcal{H} satisfies the following three conditions.

H1 (Non-Triviality) $H \in \mathcal{H} \Rightarrow H \neq \emptyset$.

H2 (Closedness under Negation) $H \in \mathcal{H} \Rightarrow H^c \in \mathcal{H}$.

H3 (Separation) for all $x \neq y$ there exists $H \in \mathcal{H}$ such that $x \in H$ and $y \notin H$.

Condition H1 says that any basic property is possessed by some element in X . Condition H2 asserts that for any basic property corresponding to H there is also the complementary property possessed by all alternatives not in H . We will refer to a pair (H, H^c) as an *issue*. Finally, condition H3 says that any two distinct elements are distinguished by at least one basic property. A pair (X, \mathcal{H}) satisfying H1-H3 will be called a *property space*.

Following Nehring (1999), a property space (X, \mathcal{H}) gives rise to a natural notion of “betweenness” of alternatives as follows.

Definition (Betweenness) Say that y is *between* x and z , denoted by $(x, y, z) \in T$, if y possesses all properties that are jointly possessed by x and z . Formally,

$$(x, y, z) \in T \Leftrightarrow [\text{for all } H \in \mathcal{H} : \{x, z\} \subseteq H \Rightarrow y \in H]. \quad (2.1)$$

The betweenness relation (2.1) has a natural interpretation in terms of *comparative*

similarity: y is between x and z whenever y is (weakly) more similar than z to x in the sense that y possesses any basic property jointly possessed by x and z . The ternary betweenness relation T induced by (X, \mathcal{H}) satisfies the following four properties (cf. Nehring (1999)). For all x, y, z, x', z' ,

T1 (Reflexivity) $y \in \{x, z\} \Rightarrow (x, y, z) \in T$.

T2 (Symmetry) $(x, y, z) \in T \Leftrightarrow (z, y, x) \in T$.

T3 (Transitivity) $[(x, x', z) \in T \text{ and } (x, z', z) \in T \text{ and } (x', y, z') \in T] \Rightarrow (x, y, z) \in T$.

T4 (Antisymmetry) $[(x, y, z) \in T \text{ and } (x, z, y) \in T] \Rightarrow y = z$.

The reflexivity condition T1 and the symmetry condition T2 follow at once from the definition of T . The transitivity condition T3 is also easily verified; it states that if both x' and z' are between x and z , and moreover y is between x' and z' , then y must also be between x and z . Finally, the antisymmetry condition T4 is due to the separation property H3.

2.2 Examples

The following list of examples illustrates the great flexibility of the notion of a property space; further examples are provided later. All of the following property spaces satisfy conditions H1-H3.

Example 1 (Lines) The simplest example is the canonical betweenness in a linearly ordered space (cf. Fig. 1a above). Specifically, assume that the alternatives can be ordered from left to right by some linear ordering \geq on X , and consider the family \mathcal{H} of all sets of the form $H_{\geq w} := \{y \geq w : \text{for some } w \in X\}$ or $H_{\leq w} := \{y \leq w : \text{for some } w \in X\}$. Each basic property is thus of the form “lying to the right of w ” or “lying to the left of w .” The induced *line betweenness* T according to (2.1) is given by

$$(x, y, z) \in T \Leftrightarrow [x \geq y \geq z \text{ or } z \geq y \geq x]$$

(see Figure 2a below).

Example 2 (The Hypercube) Let $X = \{0, 1\}^K$, which we refer to as the K -dimensional hypercube (cf. Fig. 1b). An element $x \in \{0, 1\}^K$ is thus described as a binary sequence $x = (x^1, \dots, x^K)$ with $x^k \in \{0, 1\}$. For all k , denote by $H_1^k := \{x : x^k = 1\}$ and $H_0^k := \{x : x^k = 0\}$, and consider the family \mathcal{H} of all such subsets, i.e. let $\mathcal{H} := \{H_l^k : l \in \{0, 1\}, k = 1, \dots, K\}$. Intuitively, each coordinate k corresponds to some basic property, and H_1^k (respectively, H_0^k) is the set of alternatives that possess (respectively, do not possess) the property corresponding to coordinate k . The induced *hypercube betweenness* T according to (2.1) is given as follows. For all x, y, z ,

$$(x, y, z) \in T \Leftrightarrow [\text{for all } k : x^k = z^k \Rightarrow y^k = x^k = z^k].$$

Thus, y is between x and z if and only if y agrees with x and z in each coordinate in which x and z agree. Geometrically, y is between x and z if and only if y is contained in the “subcube” spanned by x and z ; for instance, in Figure 2b below, both y and y' are between x and z ; similarly, z is between y and w (as well as between y' and w), and all elements of the pictured cube are between x and w .

Example 3 (The Vacuous Betweenness) Consider a domain (X, \mathcal{H}) such that, for all $x \in X$, $\{x\} \in \mathcal{H}$ and $X \setminus \{x\} \in \mathcal{H}$; hence, assume that for each x , “being equal to x ” and “being different from x ” are basic properties. Then, the induced betweenness T according to (2.1) is *vacuous* in the sense that, for all x, y, z ,

$$(x, y, z) \in T \Leftrightarrow y \in \{x, z\},$$

i.e. no alternative different from x and y is between these two alternatives. Indeed, consider any three distinct alternatives x, y, z , and the basic property $H = \{y\}$. Clearly, $\{x, z\} \subseteq H^c$ but $y \notin H^c$; hence, y is not between x and z (see Figure 2c below).

Example 4 (Products) The hypercube betweenness of Example 2 above is an instance of a product betweenness. Let $X = X^1 \times \dots \times X^K$, where the alternatives in each factor X^k are described by a list \mathcal{H}^k of basic properties referring to coordinate k . Let $\mathcal{H} := \{H^k \times \prod_{j \neq k} X^j : \text{for some } k \text{ and } H^k \in \mathcal{H}^k\}$, and denote by T^k the betweenness relation on X^k induced by \mathcal{H}^k . The *product betweenness* T on X according to (2.1) is given as follows. For all x, y, z ,

$$(x, y, z) \in T \Leftrightarrow [\text{for all } k : (x^k, y^k, z^k) \in T^k].$$

Figure 2d below depicts the product of two lines; the alternatives between x and z are precisely the alternatives contained in the dotted rectangle spanned by x and z .

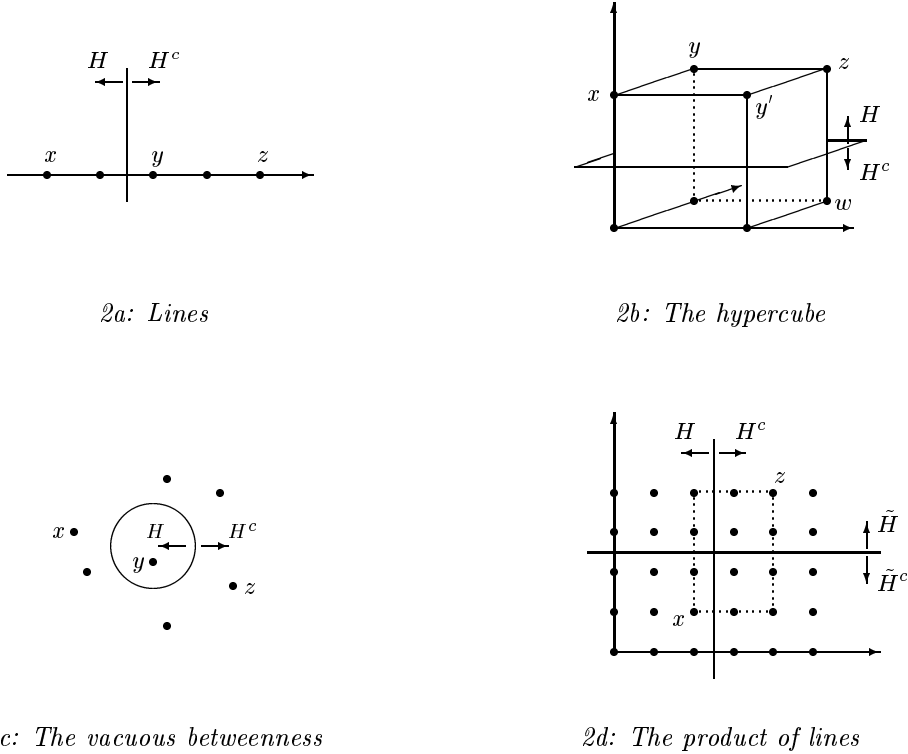

Figure 2: Basic examples of property spaces

A large class of examples of property spaces can be obtained as “graphic” spaces, as follows. A graph γ is a symmetric binary relation on X ; the elements of γ are referred to as the edges of γ . A path connecting the elements x and z in γ is a sequence of distinct elements $\{y_1, \dots, y_r\} \subseteq X$ such that $y_1 = x$, $y_r = z$, and for all $j = 1, \dots, r - 1$, $(y_j, y_{j+1}) \in \gamma$. A shortest path between two elements is a path that connects them with a minimal number of edges. Note that, in general, a shortest path is not unique. To any graph γ associate the following *graphic betweenness* T_γ (cf. Figure 1 above). For all x, y, z ,

$$(x, y, z) \in T_\gamma \Leftrightarrow y \text{ is on some shortest path connecting } x \text{ and } z. \quad (2.2)$$

Definition (Graphic Property Space) Say that a property space (X, \mathcal{H}) is a *graphic property space* if the associated betweenness relation is graphic, i.e. if there exists a graph γ such that $T = T_\gamma$, where T and T_γ are defined by (2.1) and (2.2), respectively.

Many interesting examples of property spaces are graphic; for instance, the spaces in Examples 1-3 are graphic spaces; furthermore, the product of graphic spaces is graphic.⁸ Conversely, many (though not all) graphic betweennesses can be derived from an appropriate underlying property space; for instance, this holds for all graphs depicted in Figure 1 above. Further examples include the following.

Example 5 (Trees) Consider a tree, that is, a connected and acyclic graph τ . In a tree, any two elements are connected by a unique shortest path. The basic properties underlying a tree are easily identified, as follows. Any edge (x, z) of τ naturally defines two basic properties: “lying in direction of x ” and “lying in direction of z ” (when viewed from edge (x, z)). Formally, these properties can be described by the following two subsets, $H_{\leftarrow(x,z)} := \{y : x \text{ is on a shortest path from } y \text{ to } z\}$ and $H_{(x,z)\rightarrow} := \{y : z \text{ is on a shortest path from } x \text{ to } y\}$. Let \mathcal{H} be the family of all sets of this form. Then, (X, \mathcal{H}) is a property space, and the induced *tree betweenness* T according to (2.1) coincides with the graphic betweenness induced by τ according to (2.2) (see Figure 3a). Clearly, the line betweenness of Example 1 is a special case.

Example 6 (Cycles) Let $X = \{x_1, \dots, x_l\}$, and consider the l -cycle on X , i.e. the graph with the edges (x_i, x_{i+1}) , where indices are understood modulo l so that $x_{l+1} = x_1$ (see Figure 3b for the case $l = 6$). The graphic betweenness on the l -cycle is derived from a property space as follows. If l is even, the basic properties are of the form $\{x_j, x_{j+1}, \dots, x_{j-1+\frac{l}{2}}\}$. If l is odd, the family of basic properties consists of all sets of the form $\{x_j, x_{j+1}, \dots, x_{j-1+\frac{l+1}{2}}\}$ or $\{x_j, x_{j+1}, \dots, x_{j-1+\frac{l-1}{2}}\}$.

⁸The graph that represents the line betweenness is depicted Fig. 1a above; the graph corresponding to the 3-dimensional hypercube is depicted in Fig. 1b. The graph corresponding to the vacuous betweenness on a set of six elements is depicted in Fig. 1g. Finally, the edges of the graph representing the product of two lines form a grid in which each element is connected by an edge to its north, south, east and west neighbour, respectively (cf. Fig. 1c which shows a subset of the product of two lines).

More generally, all property spaces that give rise to strategy-proof social choice without veto power (see Section 7 below) turn out to be graphic.

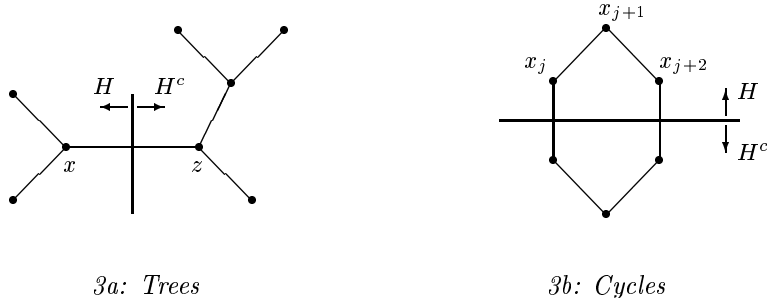

Figure 3: Further examples of graphic betweenness relations

Example 7 (The Permutahedron) Let $A = \{a, b, c, d, \dots\}$ be a finite set, and consider the set X_A of all permutations (linear orderings) of A . A typical element $x \in X_A$ is thus a bijective mapping $x : A \rightarrow \{1, 2, \dots, \#A\}$, where $\#A$ is the cardinality of A . In a social choice context, the elements of X_A can be interpreted as decision rules that govern future choices among the ultimate social states a, b, c, \dots before the feasibility constraints are known. Choosing the alternative $x \in X_A$ amounts to committing oneself to future choices according to the decision rule x . A natural class of basic properties is given by the sets of the form $H_{(a,b)} := \{x : x(a) < x(b)\}$, for every pair $(a, b) \in A \times A$ with $a \neq b$; the basic properties are thus of the form “ranks a above b .” According to (2.1), a linear ordering y is between the linear orderings x and z if y agrees in all pairwise comparisons in which x and z agree. Endowed with this betweenness, the set X_A is referred to as the *permutahedron*. To illustrate, consider a three-element set $A = \{a, b, c\}$. In this case, the permutahedron X_A is isomorphic to the 6-cycle as shown in Figure 3b. Specifically, let $x_1 = abc$, $x_2 = bac$, $x_3 = bca$, $x_4 = cba$, $x_5 = cab$ and $x_6 = acb$, where, e.g., bca denotes the linear ordering that ranks b on top, c on second and a on third position. Then, the “half-circle” $\{x_1, x_2, x_3\}$ corresponds to the basic property “ranks b above c ,” whereas $\{x_2, x_3, x_4\}$ corresponds to “ranks b above a ,” and so on. All linear orderings are between “opposite” elements, such as x_1 and x_4 , or x_2 and x_5 , or x_3 and x_6 ; finally, for any j , x_{j+1} is between x_j and x_{j+2} (with indices understood modulo 6).

2.3 Convexity

A property space (X, \mathcal{H}) gives rise to a natural notion of “convexity” of subsets as follows.

Definition (Convexity) Say that a subset $S \subseteq X$ is *convex* in the space (X, \mathcal{H}) if there exists family $\mathcal{H}_S \subseteq \mathcal{H}$ such that S is the intersection of all elements of \mathcal{H}_S , i.e. if $S = \cap \mathcal{H}_S$. Thus, a set is convex if it corresponds to some *combination* of the basic properties. By convention, we set $\cap \emptyset = X$, hence the universal set X is also convex. The terminology is justified by the observation that for any convex set S and for all x, y, z ,

$$[\{x, z\} \subseteq S \text{ and } (x, y, z) \in T] \Rightarrow y \in S. \quad (2.3)$$

Hence, if a set is convex then it contains with any two elements all elements that are between them.⁹ Note also that the intersection of convex sets is always convex.

In a graphic property space, a subset S is convex if and only if it contains with any two elements all shortest paths connecting them. For instance, a subset of a line is convex precisely if it is an *interval* with respect to the linear ordering. Similarly, the convex subsets of the hypercube are the *subcubes*, i.e. the sets of the form $S = S^1 \times \dots \times S^K$ with $\emptyset \neq S^k \subseteq \{0, 1\}$ for all k . In Example 3 of the vacuous betweenness, *all* subsets are convex. In a product (Example 4), a set S is convex if and only if it is of the form $S = S^1 \times \dots \times S^K$ where each S^k is convex in X^k .

The following additional concepts will be useful in our subsequent analysis.

Definition (Segments, Convex Hull) For any $x, z \in X$, the *segment* $[x, z]$ between x and z is defined by $[x, z] := \{y \in X : (x, y, z) \in T\}$, i.e. the segment $[x, z]$ is the set of all elements between x and y . Furthermore, for any set $A \subseteq X$, denote by *CoA* the *convex hull* of A , i.e. the smallest convex set containing A ; formally, $CoA := \cap\{H : H \supseteq A\}$. As is easily verified, the segment $[x, z]$ is the convex hull of $\{x, z\}$.

2.4 Single-Peakedness

Given a property space (X, \mathcal{H}) , the notion of a single-peaked preference is naturally defined as follows. A binary relation \succ is called a *preference ordering* if it is irreflexive and transitive, i.e. a strict partial order. Note that we thus allow for non-trivial indifference represented by the relation $x \sim y :\Leftrightarrow [\text{not } x \succ y \text{ and not } y \succ x]$. In general, the associated indifference relation need not be transitive. If the associated indifference \sim is transitive, the relation \succ is called a *weak order*; if, in addition, $x \sim y \Rightarrow x = y$, the relation \succ is called a *linear ordering*.

Definition (Single-Peakedness) A preference ordering \succ of the alternatives in X is *single-peaked* on (X, \mathcal{H}) if there exists $x^* \in X$ such that for all $y \neq z$,

$$(x^*, y, z) \in T \Rightarrow y \succ z. \quad (2.4)$$

Thus, a preference is single-peaked if there exists an alternative x^* (the “peak”) such that $y \succ z$ whenever y is between x^* and z . Equivalently, by (2.1), a preference is single-peaked if there exists x^* such that $y \succ z$ whenever $y \neq z$ and y possesses all properties jointly possessed by z and x^* , i.e. whenever y is more similar than z to x^* . Note that, by (2.4), the peak is unique since, for all z , $(x^*, x^*, z) \in T$.

In the literature, linear preferences that are single-peaked in this sense have been considered, among others, by Moulin (1980) in the case of lines, Demange (1982) in the context of trees, Barberá, Sonnenschein and Zhou (1991) in the hypercube, and Barberá, Gul and Stacchetti (1993) in the context of the product of lines. It is important to realize that single-peakedness becomes less restrictive when there are fewer instances of betweenness, i.e. when T (viewed as a subset of X^3) becomes smaller. For instance, *any* preference ordering with a unique best element is single-peaked with respect to the vacuous betweenness of Example 3 above. As another example, consider

⁹One might ask whether, conversely, any set S satisfying (2.3) is convex in the sense of the above definition. While this holds in many examples, it is not true in general. In the language of abstract convexity theory, the property that any set S satisfying (2.3) is convex is known as “2-ariness” (see van de Vel (1993)).

the permutahedron (Example 7 above). Single-peakedness of a preference among the decision rules represented by the elements of the permutahedron follows, for instance, from the assumption of expected indirect utility maximization.¹⁰

In view of its centrality, the assumption of single-peakedness deserves a closer look. In the case of a line, and more generally in all trees, single-peakedness is equivalent to the standard notion of a convex preference; but in general, convexity is too strong a condition. Say that a preference ordering \succ is *convex* if, for any x , the upper contour set $\{y \in X : y \succeq x\}$ is a convex set (in the sense of Section 2.3 above). If \succ is convex in this sense, then, for all x and all $y \neq z$,

$$[x \succeq z \text{ and } (x, y, z) \in T] \Rightarrow y \succeq z. \quad (2.5)$$

Intuitively, condition (2.5) says that a move in the direction of something preferred always yields a (weakly) preferred alternative. This may appear similar to the intuition underlying condition (2.4) defining single-peakedness. In fact, however, (2.5) is much stronger since it applies to *all* x whereas (2.4) only applies to the “ideal point” x^* . To illustrate the difference, consider the four elements x, y, y' and z in the three-dimensional hypercube as shown in Figure 2b. Without loss of generality, assume that x is the most preferred of these. Then, single-peakedness only requires that the opposite element z is the least preferred of the four elements. On the other hand, no *strict* ranking among the remaining three elements can satisfy (2.5): if z is ranked second, any move from z in direction of x would yield the less preferred alternative y or y' , respectively; if z is ranked third, there would still be one move from z in direction of x yielding a less preferred alternative; finally, if z is ranked fourth, the move from the less preferred element of $\{y, y'\}$ to z violates (2.5). This shows that *no* linear preference ordering on a hypercube can be convex.

The following characterization of single-peakedness reveals that rather than convexity, a key assumption behind single-peakedness is a notion of separability.

Proposition 2.1 *A preference ordering \succ is single-peaked on (X, \mathcal{H}) if and only if there exists a partition $\mathcal{H} = \mathcal{H}_g \cup \mathcal{H}_b$ with $\mathcal{H}_g \cap \mathcal{H}_b = \emptyset$ and $H \in \mathcal{H}_g \Leftrightarrow H^c \in \mathcal{H}_b$ such that*

- (i) $y \succ z$ whenever $y \neq z$ and $y \in H$ for all $H \in \mathcal{H}_g$ such that $z \in H$, and
- (ii) there exists x^* such that $x^* \in H$ for all $H \in \mathcal{H}_g$.

In view of condition (i), single-peakedness requires that it must be possible to partition all basic properties into a set of “good” properties (those in \mathcal{H}_g) and a set of “bad” properties (those in \mathcal{H}_b) in a *separable* way: a property is good or bad no matter with which other properties it is combined. In addition to separability, single-peakedness also requires, by condition (ii), that all good properties are jointly consistent, that is: possessed by some “ideal point” x^* . Note that in the hypercube example, condition (ii) is automatically satisfied.¹¹ Thus, in the hypercube a preference ordering is single-peaked if and only if it is separable in the sense of condition (i) alone. This explains why in the hypercube our notion of single-peakedness coincides with the notion of separability used in Barberá, Sonnenschein and Zhou (1991).

¹⁰More precisely, given any decision rule $x \in X_A$, a probability distribution on the family $2^A \setminus \{\emptyset\}$ of all possible feasibility constraints induces a probability distribution on the set A of ultimate states. A preference on the set X_A of all decision rules is single-peaked whenever these probability distributions are evaluated in accordance with expected utility maximization.

¹¹Indeed, for any partition $\mathcal{H} = \mathcal{H}^+ \cup \mathcal{H}^-$ with $H \in \mathcal{H}^+ \Leftrightarrow H^c \in \mathcal{H}^-$, the intersection $\cap \mathcal{H}^+$ is non-empty (and consists of a single element) in the case of the hypercube.

3 Voting by Committees as Voting by Properties

3.1 Definition

Let $N = \{1, \dots, n\}$ be a set of voters. Each voter i is characterized by a preference ordering \succ_i on X . Denote by x_i^* the unique best element of X with respect to \succ_i . Furthermore, let \mathcal{P} be the set of all preference orderings on X , and \mathcal{D} a generic subset of \mathcal{P} . A *social choice function* is a mapping $F : \mathcal{D}^n \rightarrow X$ that assigns to each preference profile $(\succ_1, \dots, \succ_n)$ in a domain \mathcal{D}^n a unique social alternative $F(\succ_1, \dots, \succ_n) \in X$.

An important class of social choice functions are those that only depend on the peaks of voters' preferences; these are referred to as "voting schemes" (cf. Barberá, Gul and Stacchetti (1993)). A social choice function F is a *voting scheme* if there exists a function $f : X^n \rightarrow X$ such that for all $(\succ_1, \dots, \succ_n)$, $F(\succ_1, \dots, \succ_n) = f(x_1^*, \dots, x_n^*)$, where x_i^* is voter i 's peak. In this case, we say that F satisfies *peaks only*. With slight abuse of terminology, we will also refer to any $f : X^n \rightarrow X$ as a voting scheme, since any such function f naturally induces a social choice function satisfying peaks only.

Given a description of alternatives in terms of its properties, a natural way to generate a social choice is to determine the final outcome via its properties. This is described now in detail.

Definition (Committees) A *committee* is a non-empty family \mathcal{W} of subsets of N satisfying $[W \in \mathcal{W} \text{ and } W' \supseteq W] \Rightarrow W' \in \mathcal{W}$. The coalitions in \mathcal{W} are called *winning*.

For instance, *majority voting* corresponds to $\mathcal{W}_{\frac{1}{2}} = \{W \subseteq N : \#W > \frac{1}{2} \cdot n\}$. Majority voting is a special case of *voting by quota*: for any number $q \in (0, 1)$, voting by quota q corresponds to the committee $\mathcal{W}_q = \{W \subseteq N : \#W > q \cdot n\}$.

Definition (Committee Structures) A *committee structure* on (X, \mathcal{H}) is a mapping $\mathcal{W} : \mathcal{H} \mapsto \mathcal{W}_H$ that assigns a committee to each basic property $H \in \mathcal{H}$ satisfying the following two conditions.

CS1 $W \in \mathcal{W}_H \Leftrightarrow W^c \notin \mathcal{W}_{H^c}$.

CS2 $[H \subseteq H' \text{ and } W \in \mathcal{W}_H] \Rightarrow W \in \mathcal{W}_{H'}$.

As is easily verified, CS1 implies that, for any basic property H , the committees corresponding to H and H^c are interrelated as follows (cf. Barberá, Massò and Neme (1997, Prop. 1)).

$$\mathcal{W}_H = \{W \subseteq N : W \cap W' \neq \emptyset \text{ for all } W' \in \mathcal{W}_{H^c}\}. \quad (3.1)$$

Consider now the following voting procedure, adapted to the present framework from Barberá, Sonnenschein and Zhou (1991).

Definition (Voting by Committees) Given a property space (X, \mathcal{H}) and a committee structure \mathcal{W} , *voting by committees* is the mapping $f_{\mathcal{W}} : X^n \rightarrow 2^X$ such that, for all $\xi \in X^n$,

$$x \in f_{\mathcal{W}}(\xi) :\Leftrightarrow \text{for all } H \in \mathcal{H} \text{ with } x \in H : \{i : \xi_i \in H\} \in \mathcal{W}_H. \quad (3.2)$$

In our present framework, voting by committees amounts to "voting by properties" in that each committee decides whether or not the final outcome is to have one out of two complementary basic properties. Note that $f_{\mathcal{W}}(\xi) \subseteq X$ is not assumed to be non-empty; in particular, $f_{\mathcal{W}}$ does not yet define a voting scheme in the sense of the

above definition.

Definition (Consistency) A committee structure \mathcal{W} is called *consistent* if $f_{\mathcal{W}}(\xi) \neq \emptyset$ for all $\xi \in X^n$. If \mathcal{W} is consistent, the corresponding voting procedure $f_{\mathcal{W}}$ will also be referred to as consistent.

Fact 3.1 *If $f_{\mathcal{W}}(\xi) \neq \emptyset$, then $f_{\mathcal{W}}(\xi)$ is single-valued. In particular, voting by committees defines a voting scheme whenever it is consistent.*

If $f_{\mathcal{W}}$ is consistent, one has for all H and ξ ,

$$f_{\mathcal{W}}(\xi) \in H \Leftrightarrow \{i : \xi_i \in H\} \in \mathcal{W}_H \quad (3.3)$$

by (3.2) and CS1. Since $N \in \mathcal{W}_H$ for all H , this implies that $f_{\mathcal{W}}$ satisfies *unanimity*, i.e. for all $x \in X$, $f(x, x, \dots, x) = x$. In particular, $f_{\mathcal{W}}$ is *onto* whenever it is consistent, i.e. each $x \in X$ is in the range of $f_{\mathcal{W}}$.

Voting by committees is characterized by the following monotonicity condition. Say that a voting scheme $f : X^n \rightarrow X$ is *monotone in properties* if, for all ξ, ξ', H ,

$$[f(\xi) \in H \text{ and } \{i : \xi_i \in H\} \subseteq \{i : \xi'_i \in H\}] \Rightarrow f(\xi') \in H.$$

Monotonicity in properties states that if the final outcome has some property H and the voters' support for this property does not decrease, then the resulting final outcome must have this property as well.

Proposition 3.1 *A voting scheme $f : X^n \rightarrow X$ is monotone in properties and onto if and only if it is voting by committees with a consistent committee structure.*

3.2 The Equivalence of Strategy-Proofness and Voting by Committees

A social choice function $F : \mathcal{D}^n \rightarrow X$ is *strategy-proof* on \mathcal{D} if for all i and $\succ_i, \succ'_i \in \mathcal{D}$,

$$F(\succ_1, \dots, \succ_i, \dots, \succ_n) \succeq_i F(\succ_1, \dots, \succ'_i, \dots, \succ_n).$$

Furthermore, say that F satisfies *voter sovereignty* if F is onto, i.e. if any $x \in X$ is in the range of F . For any committee structure \mathcal{W} , denote by $F_{\mathcal{W}} : \mathcal{D}^n \rightarrow 2^X$ the mapping defined by $F_{\mathcal{W}}(\succ_1, \dots, \succ_n) = f_{\mathcal{W}}(x_1^*, \dots, x_n^*)$, where for each i , x_i^* is the peak of \succ_i on X . The mapping $F_{\mathcal{W}}$ will also be referred as voting by committees. Denote by $\mathcal{S}_{(X, \mathcal{H})}$ the set of all single-peaked preferences (strict partial orders) on (X, \mathcal{H}) ; we will refer to $[\mathcal{S}_{(X, \mathcal{H})}]^n$ as a *single-peaked domain*. When no confusion can arise, we will simply write \mathcal{S} for $\mathcal{S}_{(X, \mathcal{H})}$.

Proposition 3.2 *Let $F : \mathcal{S}^n \rightarrow X$ be represented by the voting scheme $f : X^n \rightarrow X$. Then, F is strategy-proof on \mathcal{S} if and only if f is monotone in properties.*

In combination with Proposition 3.1, this implies that a voting scheme is strategy-proof on the domain of all single-peaked preferences if and only if it is voting by committees with a consistent committee structure. We now want to show that *any* strategy-proof social choice function $F : \mathcal{S}^n \rightarrow X$ satisfying voter sovereignty is voting by committees. For this, it remains to show that any such F is a voting scheme, i.e. that it satisfies peaks only.

Proposition 3.3 (Barberá, Massò and Neme) *Every strategy-proof social choice function $F : S^n \rightarrow X$ that satisfies voter sovereignty is a voting scheme, i.e. satisfies peaks only.*

The proof of Proposition 3.3 provided in the appendix is a translation of Proposition 2 in Barberá, Massò and Neme (1997). However, we cannot directly invoke their result since it is formulated for certain subdomains of single-peaked preferences on a product of lines. The main step that allows the translation is provided by the following fact, which is well-known in the literature on abstract convexity theory (see, e.g., van de Vel (1993)).

Fact 3.2 *Any property space (X, \mathcal{H}) is isomorphic to a subset $Y \subseteq \{0, 1\}^K$ of a hypercube with $K = (\#\mathcal{H})/2$.*

Combining Propositions 3.1 – 3.3, we obtain the following result which generalizes corresponding results of Barberá, Sonnenschein and Zhou (1991) for the case of the hypercube and Barberá, Gul and Stacchetti (1993) for the case of the product of lines.

Theorem 1 *A social choice function $F : S^n \rightarrow X$ satisfies voter sovereignty and is strategy-proof on S if and only if it is voting by committees with a consistent committee structure.*

3.3 Anonymity and Neutrality

A social choice function F is called *anonymous* if it is invariant with respect to permutations of individual preferences; similarly, a voting scheme f is called anonymous if $f(\xi_1, \dots, \xi_n) = f(\xi_{\sigma(1)}, \dots, \xi_{\sigma(n)})$ for any permutation $\sigma : N \rightarrow N$. The following fact is easily verified; the second part follows at once from (3.1).

Fact 3.3 *Voting by committees $f_{\mathcal{W}}$ is anonymous if and only if it is voting by quota, i.e. for all H there exists $q_H \in [0, 1]$ such that $\mathcal{W}_H = \{W : \#W > q_H \cdot n\}$ if $q_H < 1$ and $\mathcal{W}_H = \{N\}$ if $q_H = 1$.¹² If $f_{\mathcal{W}}$ is consistent, the quotas can be chosen such that, for all $H \in \mathcal{H}$, $q_{H^c} = 1 - q_H$.*

In the following definition, we call a profile $(\succ_1, \dots, \succ_n)$ *simple* if $\#\{\succ_1, \dots, \succ_n\} \leq 2$, i.e. if it contains at most two different preference orderings.

Definition (Neutrality) Say that a social choice function F is *neutral* if it satisfies the following condition. For all simple profiles $(\succ_1, \dots, \succ_n)$, $(\succ'_1, \dots, \succ'_n)$ and all permutations $\sigma : X \rightarrow X$ such that $x \succ_i y \Leftrightarrow \sigma(x) \succ'_i \sigma(y)$ for all x, y and i ,

$$F(\succ'_1, \dots, \succ'_n) = \sigma(F(\succ_1, \dots, \succ_n)).$$

Similarly, a voting scheme f is called neutral whenever the induced social choice function F is neutral.

Proposition 3.4 a) *Voting by committees is neutral if and only if, for all $H, H' \in \mathcal{H}$, $\mathcal{W}_H = \mathcal{W}_{H'}$.*

b) *Voting by committees is anonymous and neutral if and only if it is issue-by-issue majority voting with an odd number of voters, i.e. if and only if n is odd and, for all H , \mathcal{W}_H corresponds to voting by quota $q_H = \frac{1}{2}$.*

¹²Note that the quotas q_H are not uniquely determined.

3.4 Consistent Committee Structures: The Intersection Property

By Theorem 1 above, a social choice function is strategy-proof on a domain of single-peaked preferences if and only if it is *consistent* voting by committees. It is, however, not self-evident whether a given committee structure is consistent. The needed characterization of consistency is provided in this subsection. As a simple example of an inconsistent committee structure, consider the vacuous betweenness on $X = \{x, y, z\}$, and assume that voting by committees takes the form of issue-by-issue majority voting among three voters. If all three peaks of the voters are distinct, each of the following basic properties gets a majority of two votes: $\{y, z\}$ (“being different from x ”), $\{x, z\}$ (“being different from y ”), and $\{x, y\}$ (“being different from z ”). But clearly, $\{y, z\} \cap \{x, z\} \cap \{x, y\} = \emptyset$, i.e. the basic properties determined by the committees are jointly incompatible. Consistency of voting by committees requires that the committee structure be compatible with the structure of basic properties, as follows.

Definition (Critical Family) Say that a family $\mathcal{G} \subseteq \mathcal{H}$ of basic properties is a *critical family* if $\bigcap \mathcal{G} = \emptyset$ and for all $G \in \mathcal{G}$, $\bigcap (\mathcal{G} \setminus \{G\}) \neq \emptyset$.

The interpretation of a critical family is as an exclusion of a certain combination of basic properties. “Criticality” (i.e. minimality) means that this exclusion is not already entailed by a more general exclusion. More concretely, consider $\mathcal{G} = \{G_1, \dots, G_l\}$; to say that \mathcal{G} is a critical family is to say that for any combination of $l - 1$ basic properties in \mathcal{G} there are states possessing them jointly, but any state possessing $l - 1$ of the basic properties cannot possess the remaining l -th property. Thus, critical families reflect the “entailment logic” of the underlying property space, a theme explored in more detail in Section 4.3 below. Trivial instances of critical families are all pairs $\{H, H^c\}$ of complementary properties. A non-trivial example of a critical family are the three basic properties $\{y, z\}$, $\{x, z\}$ and $\{x, y\}$ in the above example of the set $\{x, y, z\}$ endowed with the vacuous betweenness: any two of these basic properties have a non-empty intersection, while the intersection of all three is empty.

Intersection Property Say that voting by committees $F_{\mathcal{W}}$ satisfies the *Intersection Property* if for any critical family $\mathcal{G} = \{G_1, \dots, G_l\}$, and any selection $W_j \in \mathcal{W}_{G_j}$,

$$\bigcap_{j=1}^l W_j \neq \emptyset.$$

Using (3.1), it is easily verified that the Intersection Property applied to critical families with two elements yields precisely conditions CS1 and CS2 above.

Proposition 3.5 *Voting by committees is consistent if and only if it satisfies the Intersection Property.*

Combining this result with Theorem 1, we obtain the following characterization of all strategy-proof social choice functions on single-peaked domains.

Theorem 2 *A social choice function $F : S^n \rightarrow X$ satisfies voter sovereignty and is strategy-proof on S if and only if it is voting by committees satisfying the Intersection Property.*

Theorem 2 generalizes a corresponding result of Barberá, Massò and Neme (1997, Corollary 3) in the context of single-peaked domains on subsets of a product of lines. In that context, these authors already provided a necessary and sufficient condition, also called the “intersection property.” However, their condition is less transparent and workable than the one given above. The simplicity of our characterization is due to the concept of critical family, which allows one to formulate the Intersection Property as a condition on the non-emptiness of certain intersections of winning coalitions; by contrast, the condition used in Barberá, Massò and Neme (1997) requires, for all subsets of X , the non-emptiness of certain intersections of appropriate *unions* of winning coalitions.¹³

In the anonymous case, the Intersection Property can be formulated as follows. If, for any critical family \mathcal{G} ,

$$\sum_{H \in \mathcal{G}} q_H \geq \#\mathcal{G} - 1, \quad (3.4)$$

then voting by quotas q_H for $H \in \mathcal{H}$ is consistent. Conversely, if anonymous voting by committees is consistent, then it can be represented by quotas satisfying (3.4). Observe that this immediately implies that issue-by-issue majority voting is consistent if and only if any critical family has two members.

To illustrate the intuition behind the Intersection Property, we verify the necessity of (3.4) in the special case of the vacuous betweenness on $X = \{x_1, \dots, x_m\}$; from this it is straightforward to infer the non-existence of anonymous and strategy-proof social choice functions on an unrestricted domain if $m \geq 3$. Recall from Example 3 that the vacuous betweenness corresponds to the basic properties $H_j = \{x_j\}$ (“being equal to x_j ”) and $H_j^c = X \setminus \{x_j\}$ (“being different from x_j ”), for $j = 1, \dots, m$. The non-trivial critical families are $\{H_1^c, \dots, H_m^c\}$ and, for all $j \neq k$, $\{H_j, H_k\}$. Consider the critical family $\{H_1^c, \dots, H_m^c\}$, and suppose that (3.4) is violated, i.e. $\sum_j q_j^c < m - 1$, where q_j^c denotes the quota corresponding to H_j^c . If q_j is the quota corresponding to H_j , one thus obtains $\sum_j q_j > 1$, say $\sum_j q_j = 1 + m \cdot \delta$ for some $\delta > 0$. Now assign to a fraction of $q_j - \delta$ voters the peak x_j . Since none of the basic properties $H_j = \{x_j\}$ reaches the quota, all complements are enforced; but since their intersection is empty, consistency is violated.

4 Strong Possibility on Median Spaces

By Theorem 2 above, strategy-proof social choice on single-peaked domains takes the form of voting by committees satisfying the Intersection Property. For any *given* domain this yields a simple characterization of non-manipulable social choice under single-peakedness. We now want to ask the following question: For which property spaces do there *exist* well-behaved strategy-proof social choice functions on the associated domain of single-peaked preferences? In this section, we first derive a simple necessary and sufficient condition on a property space such that *all* well-defined committee structures are consistent. We then show that the same condition also characterizes the class of single-peaked domains that admit neutral and non-dictatorial social choice rules.

¹³Specifically, the logical form of the intersection property used in Barberá, Massò and Neme (1997) translated to our framework is as follows. For all families \mathcal{G} with $H \in \mathcal{G} \Rightarrow H^c \notin \mathcal{G}$ and $\cap \mathcal{G} = \emptyset$, for all subsets $A \subseteq X$, and for all selections $W_H \in \mathcal{W}_H$: $\bigcap_{x \in A} (\bigcup_{H \in \mathcal{F}_{x, \mathcal{G}}} W_H) \neq \emptyset$, for appropriately chosen families $\mathcal{F}_{x, \mathcal{G}} \subseteq \mathcal{H}$ (depending on $x \in A$ and \mathcal{G}).

The property spaces considered in this section thus enable well-behaved strategy-proof social choice in a very strong sense. In the subsequent sections, we will consider in turn weaker notions of “well-behavedness” such as the absence of dictators, anonymity, and no veto, respectively.

4.1 Universal Consistency of Median Spaces

As an immediate consequence of (3.4), we have seen that issue-by-issue majority voting is consistent if and only if every critical family has only two elements. What does that mean geometrically? To provide the intuition, consider three voters with peaks ξ_1, ξ_2, ξ_3 and denote by m the chosen state under issue-by-issue majority voting. Consider any basic property H possessed by both ξ_1 and ξ_2 , i.e. assume that $\{\xi_1, \xi_2\} \subseteq H$. Then H gets a majority of at least two votes over H^c , hence we must have $m \in H$ (see Figure 4 below). By (2.1), this means that m must lie between ξ_1 and ξ_2 . But the same argument applies to any basic property jointly possessed by ξ_1 and ξ_3 , and to any basic property jointly possessed by ξ_2 and ξ_3 . In other words, a necessary condition for issue-by-issue majority voting to be consistent is that any triple ξ_1, ξ_2, ξ_3 of social states admits a state $m = m(\xi_1, \xi_2, \xi_3)$ that is between any pair of them. Such a state will be called a “median” of the triple.

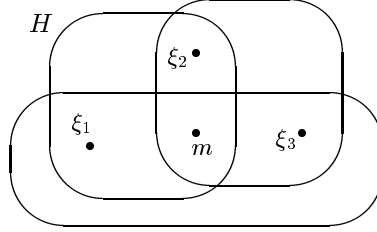

Figure 4: The median property

Definition (Median Space) A property space (X, \mathcal{H}) is called a *median space* if the induced betweenness relation T satisfies the following condition. For all $x, y, z \in X$ there exists an element $m = m(x, y, z) \in X$, called a *median* of x, y, z , such that m is between any pair of $\{x, y, z\}$, i.e. such that $m \in [x, y] \cap [x, z] \cap [y, z]$.

Median spaces are a classic topic in abstract convexity theory (see, e.g., Bandelt and Hedlíková (1983) and the references in van de Vel (1993)).

Fact 4.1 *In a median space, any triple has a unique median.*

Median spaces can be characterized in terms of the underlying properties \mathcal{H} as follows. Say that a family $\mathcal{A} \subseteq 2^X$ of subsets of X has the *pairwise intersection property* if for any collection $A_1, \dots, A_l \in \mathcal{A}$ such that $A_k \cap A_h \neq \emptyset$ for all $k, h \in \{1, \dots, l\}$, one has $\bigcap_{k=1}^l A_k \neq \emptyset$.

Proposition 4.1 *The following statements are equivalent.*

- (i) (X, \mathcal{H}) is a median space.
- (ii) \mathcal{H} has the pairwise intersection property.
- (iii) Any family of convex subsets has the pairwise intersection property.
- (iv) For all critical families \mathcal{G} , $\#\mathcal{G} = 2$.

Thus, a property space is a median space if pairwise compatibility of a family of basic properties implies their joint compatibility. Note that in contrast to the Intersection Property for committees, the pairwise intersection property imposes a restriction only on the space (X, \mathcal{H}) .

The existence of a median for any triple is not only necessary for the consistency of issue-by-issue majority voting but also sufficient; in fact, it turns out to be sufficient for the consistency of *any* well-defined committee structure.

Definition (Universal Consistency) Say that a property space (X, \mathcal{H}) is *universally consistent* if voting by committees $f_{\mathcal{W}}$ is consistent for any committee structure \mathcal{W} (satisfying CS1 and CS2).

Theorem 3 *A property space (X, \mathcal{H}) is universally consistent if and only if it is a median space.*

The proof of the sufficiency part of Theorem 3 is an easy consequence of two results that have already been established. By Proposition 4.1, all critical families in a median space have cardinality two. But for such critical families, the Intersection Property of Section 3.4 reduces to the requirements CS1 and CS2. Hence, by Proposition 3.5, any committee structure satisfying these two requirements is consistent.

Theorem 3 has the following corollary which shows that median spaces admit a maximal class of strategy-proof social choice functions.¹⁴

Corollary 4.1 *Let (X, \mathcal{H}) be a median space. A social choice function $F : S^n \rightarrow X$ is strategy-proof and onto if and only if F is voting by committees with an arbitrary well-defined committee structure.*

To assess the extent to which the above results can be viewed as possibility results, it is crucial to determine how large the class of median spaces is. Since y is the median of x, y, z whenever y is between x and z , lines (Ex. 1 above) are median spaces with the middle point as the median of any triple. More generally, all trees (Ex. 5) are median spaces.¹⁵ Furthermore, all hypercubes (Ex. 2) are median spaces; typical configurations are the triple x, z, w with the median y in Fig. 1b above, or the triple y, y', w with median z in Fig. 2b. More generally, any distributive lattice is a median space (see van de Vel (1993)). In addition, products (Ex. 4) are median spaces if and only if every factor is a median space; indeed, the median on a product is simply given by taking the median in any coordinate.

On the other hand, Examples 3, 6 and 7 are not median spaces whenever $\#X \geq 3$ (with the exception of the 4-cycle which is isomorphic to the two-dimensional hypercube). For instance, if a space is endowed with the vacuous betweenness (Ex. 3), *no* triple of pairwise distinct alternatives admits a median. The fact that neither cycles (Ex. 6) nor permutahedra (Ex. 7) are median spaces is exemplified by the triple x, z, w in Fig. 1h above.

Further examples of median spaces are appropriate subdomains of median spaces.

¹⁴We assume voter sovereignty from now on without always mentioning that condition in the text. In our formal statements, we refer to the condition of voter sovereignty by requiring the relevant social choice functions to be onto.

¹⁵To see this, consider for any triple of points the (unique) shortest paths connecting any pair. By the acyclicity of the underlying graph, these three shortest paths must have exactly one point in common, namely the median of the triple.

Definition (Median Stability) A subset $Y \subseteq X$ of a median space (X, \mathcal{H}) is called *median stable* if $m(x, y, z) \in Y$ for all $\{x, y, z\} \subseteq Y$.

For instance, any subset of the form $\{x, y, z, m\}$ where m is the median of x, y, z is median stable. Given a property space (X, \mathcal{H}) and a subset $Y \subseteq X$, denote by $\mathcal{H}|_Y := \{H \cap Y : H \in \mathcal{H}\}$ the *relativization* of \mathcal{H} to Y . As is easily verified, $(Y, \mathcal{H}|_Y)$ is a median space if and only if Y is a median stable subset of X . The class of all median stable subsets admits the following simple characterization (cf. van de Vel (1993, p.130)).

Proposition 4.2 *Let (X, \mathcal{H}) be a median space, and let $H, H' \in \mathcal{H}$. Then, the set $Y = X \setminus (H \cap H')$ is median stable. Moreover, all median stable subsets of X are obtained by sequentially deleting intersections of two basic properties.*

The following figure depicts a typical median stable subset of the product of two lines; its median stability is easily verified using Proposition 4.2 (for another example, see Fig. 1c above).

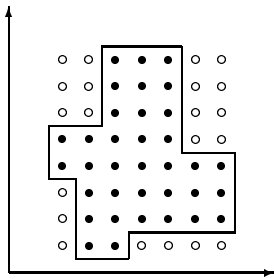

Figure 5: A median stable subset of the product of two lines

4.2 Neutrality and Strategy-Proofness Require a Median Space

We have seen that issue-by-issue majority voting is consistent only on median spaces. In view of Proposition 3.4b, this means that only on median spaces there can exist strategy-proof social choice functions that are anonymous and neutral. In this subsection, we strengthen this result by showing that neutrality alone requires a median space, unless the social choice is dictatorial.

A social choice function $F : \mathcal{D}^n \rightarrow X$ is called *dictatorial* if there exists a voter $i \in N$ such that for all profiles $(\succ_1, \dots, \succ_n)$, $F(\succ_1, \dots, \succ_n) = x_i^*$ where x_i^* is the peak of \succ_i . It is immediate that voting by committees $F_{\mathcal{W}}$ is dictatorial on \mathcal{S}^n with dictator i if and only if $\{i\} \in \mathcal{W}_H$ for all $H \in \mathcal{H}$. To see this, choose, for any $H \in \mathcal{H}$, a single-peaked preference \succ_i with peak in H , and let all peaks of the other voters be in H^c . Since i can enforce her most preferred alternative, i alone must be winning for H .

Theorem 4 *Suppose that the social choice function $F : [\mathcal{S}_{(X, \mathcal{H})}]^n \rightarrow X$ is strategy-proof, neutral, non-dictatorial and onto. Then (X, \mathcal{H}) is a median space and n is odd. Conversely, for any median space (X, \mathcal{H}) and any family $\mathcal{W}_0 \subseteq 2^N \setminus \{\emptyset\}$ that is closed under taking supersets and satisfies $W \in \mathcal{W}_0 \Leftrightarrow W^c \notin \mathcal{W}_0$, voting by committees $F_{\mathcal{W}}$ with $\mathcal{W}_H = \mathcal{W}_0$ for all $H \in \mathcal{H}$ is consistent.*

The idea of the proof of the first statement in Theorem 4 is as follows. Since F is strategy-proof and onto, it must have the structure of voting by committees; by neutrality, the committees assigned to all basic properties are identical, say $\mathcal{W}_H = \mathcal{W}_0$ for all H . Assume, by way of contradiction, that (X, \mathcal{H}) is not a median space. Then, by Proposition 4.1, there exists a critical family with at least three elements. By the Intersection Property, this implies that any three winning coalitions in \mathcal{W}_0 must have a non-empty intersection. Using CS1, we show in the appendix that this implies $\{i\} \in \mathcal{W}_0$ for some $i \in N$, hence voter i is a dictator.

Note that Theorem 4 as well as other possibility results below assert the existence of a strategy-proof social choice function satisfying specified properties for *some* number n of voters; here for n odd, elsewhere for n sufficiently large.

4.3 The Nature of Median Spaces

Our results suggest that the notion of a critical family of basic properties plays a key role for the understanding of voting by committees and thus of strategy-proof social choice on single-peaked domains. We have already noted that a critical family describes certain entailments among basic properties. Since a property space is uniquely identified through its critical families, this means that the critical families describe a property space in terms of its “entailment logic.” To illustrate, consider the line, labelled by the natural numbers $1, \dots, m$. The basic properties are “being greater than or equal to” and “being smaller than or equal to” any number between 1 and m . All critical families have the following form: for some $k < j$, “being greater than or equal to j and smaller than or equal to k .” The interpretation is that “ $\geq j$ ” logically entails “not $\leq k$ ” whenever $k < j$. Thus, the critical family corresponds to the statement “for all x , $x \geq j$ implies (not $x \leq k$).” In this case, the entailment is “simple” in that the antecedent of the implication consists of *one* basic property.

By contrast, consider the permutahedron X_A , i.e. the set of all linear orderings over a set A of ultimate states and recall that the basic properties have the form “ranks a above b ” for some $a, b \in A$ (cf. Example 7 above). For simplicity assume $\#A = 3$. In that case, the non-trivial critical families are triples of basic properties of the form “ranks a above b ,” “ranks b above c ” and “ranks c above a .” A critical family thus describes the implication “if a is ranked above b , and b is ranked above c , then c cannot be ranked above a .” The entailment logic underlying the permutahedron thus simply reflects the transitivity of linear orderings. Note that the antecedent of the relevant implication consists of the conjunction of *two* basic properties in that case.

As another example, consider the set $X = \{x_1, \dots, x_m\}$ endowed with the vacuous betweenness. For each x_j , the set $H_j^c = X \setminus \{x_j\}$ corresponds to the basic property “being different from x_j .” The critical family $\{H_1^c, \dots, H_m^c\}$ thus describes the following entailment: “if an alternative is different from $m - 1$ distinct elements of X , it cannot be different from the remaining m -th element.” The antecedent of this implication is still more complex as it consists of $m - 1$ conjunctions of basic properties.

The characterization of median spaces as those property spaces for which all critical families have cardinality two (cf. Proposition 4.1) thus says that median spaces are those property spaces with a simple entailment logic. This singles out median spaces as a fundamental class of property spaces.

As a more concrete illustration, consider the following problem of *constitutional choice*. Suppose that a set of countries, say the EU member states, have to decide

on the procedures for their collective choices, i.e. they have to decide on their joint constitution. Specifically, consider the problem of determining on which of the issues $K = \{1, \dots, k\}$ future decisions are to be made on the basis of majority voting.¹⁶ Individual preferences are thus taken to be over subsets of K with the interpretation that $L \succ_i L'$ if country i prefers majority voting over exactly the issues in $L \subseteq K$ to majority voting over exactly the issues in $L' \subseteq K$. The assumption of single-peakedness does not seem implausible in that context; it requires that, for each single issue k , majority voting over issue k is preferred/not preferred independently of the corresponding preference over other issues. Observe, however, that this excludes a preference for the overall extent of majority voting (regardless on which issues), since in that case majority voting for one issue would be a substitute for majority voting over another issue.

In general, one cannot assume that the issues are independent from each other. In other words, one has to account for the “entailment logic” of the underlying problem. For instance, suppose that the issue k represents the joint defense policy of the countries, whereas k' represents their joint foreign policy. It is in general not possible to decide on defense policy by majority voting without also deciding at least on some foreign policy issues by majority voting. In particular, the set of all feasible constitutions will, in general, not be the entire power set 2^K . The entailment “majority voting over $k \Rightarrow$ majority voting over k' ” thus corresponds to a critical family. As long as all such entailments are simple in the sense that their antecedent consists of only one basic property, the resulting space is a median space. By Theorem 3 above, any well-defined voting by committees procedure is applicable in that case.

5 Impossibility on Totally Blocked Spaces

5.1 Generalizing the Gibbard-Satterthwaite Theorem

The strong possibility results on median spaces established in the previous section contrast with the well-known Gibbard-Satterthwaite Impossibility Theorem for an unrestricted preference domain. In this subsection, we generalize that result by characterizing the class of property spaces for which all strategy-proof social choice functions on the associated single-peaked domain are dictatorial.

The following binary relation on \mathcal{H} turns out to play a fundamental role in all what follows.

Definition (Conditional Entailment) For all $H, G \in \mathcal{H}$,

$$H \geq^0 G :\Leftrightarrow [H \neq G^c \text{ and there exists a critical family } \mathcal{G} \text{ with } \mathcal{G} \supseteq \{H, G^c\}]$$

Intuitively, $H \geq^0 G$ means that, given *some* combination of other basic properties, the basic property H “entails” the basic property G . More precisely, let $H \geq^0 G$, i.e. let $\{H, G^c, G_1, \dots, G_l\}$ be a critical family; then with $S = \bigcap_{j=1}^l G_j$ one has both $S \cap H \neq \emptyset$ (“property H is compatible with the combination S of properties”) and $S \cap G^c \neq \emptyset$ (“property G^c is compatible with S as well”) but $S \cap H \cap G^c = \emptyset$ (“properties H and G^c are jointly incompatible with S ”).

¹⁶The difficult negotiations among the EU countries during the 2000 summit meeting in Nice demonstrated the importance of this problem; they also made clear the relevance of strategic considerations.

Note that the relation \geq^0 is reflexive (since any pair $\{H, H^c\}$ is critical) and *complementation-adapted* in the sense that $H \geq^0 G \Leftrightarrow G^c \geq^0 H^c$. Furthermore, $H \subseteq G \Rightarrow H \geq^0 G$, since $H \subseteq G$ implies that $\{H, G^c\}$ is a critical family.

In median spaces, the conditional entailment relation coincides with the subhood-relation, i.e. $H \geq^0 G \Leftrightarrow H \subseteq G$, by Proposition 4.1(iv). In particular, in median spaces conditional entailment is a transitive relation. This does not hold in general, and it will be useful to consider the *transitive closure* of \geq^0 , which we denote by \geq . Clearly, \geq is transitive, reflexive and complementation-adapted. The symmetric part of \geq is denoted by $H \equiv G \Leftrightarrow [H \geq G \text{ and } G \geq H]$.

As an illustration, consider again the 6-cycle (cf. Fig. 1h and Fig. 3b above) and the seven-point graph in Fig. 1d above. For the present purpose, it is convenient to picture these graphs as embedded in a hypercube. The following figure shows the embedded graphs.

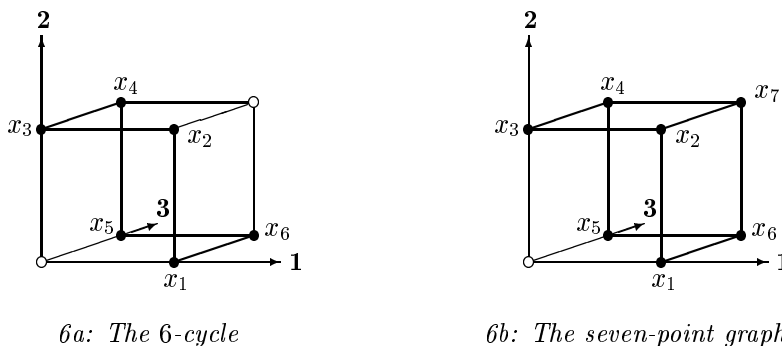

Figure 6: Two graphs embedded in the three-dimensional hypercube

As in Example 2 above, denote by H_0^k the basic property corresponding to a zero in coordinate k , and by H_1^k the basic property corresponding to a one in coordinate k (in Figure 6, the origin $(0,0,0)$ is the left-bottom-front point). Thus, for instance in Figure 6a, the set H_1^1 (the right face of the cube) consists of the three points x_1, x_2 and x_6 ; similarly, for the set H_0^2 (the bottom face) one has $H_0^2 = \{x_1, x_5, x_6\}$. In Figure 6b, on the other hand, one has $H_1^1 = \{x_1, x_2, x_6, x_7\}$ and again $H_0^2 = \{x_1, x_5, x_6\}$.

Viewed as a subspace of the three-dimensional hypercube, the seven-point subset in Figure 6b is characterized by the following, single non-trivial critical family:¹⁷ $\mathcal{G}_0 := \{H_0^1, H_0^2, H_0^3\}$. Indeed, one has $\cap \mathcal{G}_0 = \emptyset$ corresponding to the fact that no element is simultaneously in the left, bottom and front faces of the cube. On the other hand, any two basic properties in \mathcal{G}_0 have a non-empty intersection, e.g. $H_0^1 \cap H_0^2 = \{x_5\}$. In terms of conditional entailment, criticality of \mathcal{G}_0 implies that $H_0^k \geq^0 H_1^{k'}$ for $k \neq k'$. Since there are no other non-trivial critical families, these are the only instances of conditional entailment in Figure 6b (besides those implied by reflexivity).

By contrast, consider the 6-cycle in Figure 6a, which is characterized by the two critical families $\mathcal{G}_0 = \{H_0^1, H_0^2, H_0^3\}$ (no element is simultaneously in the left, bottom and front faces) and $\mathcal{G}_1 := \{H_1^1, H_1^2, H_1^3\}$ (no element is simultaneously in the right, top and back faces). Here, one has $H_0^k \geq^0 H_1^{k'}$ for all $k \neq k'$, and symmetrically,

¹⁷More precisely, a set $X \subseteq \{0,1\}^K$ viewed as a subspace of the hypercube is the pair $(X, \mathcal{H}|_X)$, where $(\{0,1\}^K, \mathcal{H})$ is the hypercube property space and $\mathcal{H}|_X = \{H \cap X : H \in \mathcal{H}\}$. In the following, we will keep this implicit whenever we consider subsets as subspaces.

$H_1^k \geq^0 H_0^{k'}$ for all $k \neq k'$. This implies at once that for the 6-cycle, one has $H \equiv G$ for all basic properties H and G . Spaces with that property will be called “totally blocked.”

Definition (Total Blockedness) Say that a property space (X, \mathcal{H}) is *totally blocked* if for the induced conditional entailment relation, $H \equiv G$ for all $H, G \in \mathcal{H}$.

The central role of conditional entailment derives from the following observation which is a straightforward consequence of the Intersection Property.

Fact 5.1 *Consider voting by committees $F_{\mathcal{W}} : \mathcal{S}^n \rightarrow X$ with a consistent committee structure \mathcal{W} . Then, for any pair of basic properties, $H \geq G \Rightarrow \mathcal{W}_H \subseteq \mathcal{W}_G$.*

To verify this, it suffices to show that $H \geq^0 G \Rightarrow \mathcal{W}_H \subseteq \mathcal{W}_G$. Thus, suppose that $\{H, G^c\} \subseteq \mathcal{G}$ for some critical family \mathcal{G} . By the Intersection Property, $W \cap W' \neq \emptyset$ for any $W \in \mathcal{W}_H$ and any $W' \in \mathcal{W}_{G^c}$. By (3.1), this implies $\mathcal{W}_H \subseteq \mathcal{W}_G$. Note that in the anonymous case, the restriction $\mathcal{W}_H \subseteq \mathcal{W}_G$ amounts to $q_H \geq q_G$.

By Fact 5.1, conditional entailment forces a strong relationship between the corresponding committees: if $H \geq G$, then any coalition that is winning for H (over its complement) must also be winning for G (over its complement).

Theorem 5 (General Impossibility Result) *Let (X, \mathcal{H}) be a property space. Any onto strategy-proof social choice function $F : \mathcal{S}^n \rightarrow X$ is dictatorial if and only if (X, \mathcal{H}) is totally blocked.*

That any strategy-proof social choice function $F : \mathcal{S}^n \rightarrow X$ on a totally blocked space must be dictatorial is an easy consequence of Theorem 4. Indeed, suppose that (X, \mathcal{H}) is totally blocked. Then, by Fact 5.1, any consistent committee structure on (X, \mathcal{H}) must be neutral, i.e. $\mathcal{W}_H = \mathcal{W}_0$ for some \mathcal{W}_0 and all $H \in \mathcal{H}$. But by Theorem 4, neutral and non-dictatorial social choice on single-peaked domains requires a median space. But clearly, a totally blocked space cannot be a median space; hence all strategy-proof social choice functions $F : \mathcal{S}^n \rightarrow X$ must be dictatorial. The proof of the converse statement is provided in the appendix.

Corollary (The Gibbard-Satterthwaite Theorem) *If X contains three or more elements, then all onto strategy-proof social choice functions defined on an unrestricted domain of preferences are dictatorial.*

To see how the Gibbard-Satterthwaite Theorem follows from Theorem 5, consider the set $X = \{x_1, \dots, x_m\}$ with the vacuous betweenness. Recall that this corresponds to taking $H_j = \{x_j\}$ (“being equal to x_j ”) and $H_j^c = X \setminus \{x_j\}$ (“being different from x_j ”), for all $j = 1, \dots, m$, as the basic properties. Given $\mathcal{H} := \{H_1, \dots, H_m\} \cup \{H_1^c, \dots, H_m^c\}$, any preference on (X, \mathcal{H}) with a unique best element is single-peaked, i.e. \mathcal{S}^n is the unrestricted domain. The (non-trivial) critical families are $\{H_1^c, \dots, H_m^c\}$ and, for any $j \neq k$, $\{H_j, H_k\}$. If $m \geq 3$, this implies at once that (X, \mathcal{H}) is totally blocked, hence the conclusion by Theorem 5.

The Gibbard-Satterthwaite Theorem itself has been derived before from the characterization of strategy-proof social choice in terms of voting by committees by Barberá, Massó and Neme (1997); however, these authors do not provide a general impossibility result in the manner of Theorem 5. There are now many different proofs of the Gibbard-Satterthwaite Theorem available in the literature; see, among others, Benoit (2000), Reny (2001) and Sen (2001).

Recently, Aswal, Chatterji and Sen (2002) have generalized the Gibbard-Satterthwaite Theorem in a different direction. Specifically, they identify a class of (not necessarily single-peaked) domains, the so-called “linked” domains, and show that any strategy-proof social choice function on a linked domain must be dictatorial. However, this only yields a coarse sufficient condition for dictatorship, since many dictatorial domains are not linked. For instance, it is easily shown that if a single-peaked domain on a graphic space is linked, then the space must contain a convex 3-cycle. This implies, e.g., that the domain of all single-peaked linear orderings on an l -cycle is linked if and only if $l = 3$; but these domains are dictatorial also for all $l > 4$, by Proposition 5.1a) below. By contrast, Theorem 5 above provides a *characterization* of the class of all dictatorial domains under the additional “regularity” condition of single-peakedness.

We conclude this section by providing examples of dictatorial domains besides the unrestricted domain.

Example 8 Consider the hypercube $\{0, 1\}^K$ and the subset X of all binary sequences with at least k and at most k' coordinates having the entry 1, where $k \leq k'$. For instance, for $K = 3$, $k = 1$ and $k' = 2$ this corresponds to the 6-cycle in Figure 6a. The critical families of the resulting space are all subsets of $\{H_1^1, H_1^2, \dots, H_1^K\}$ with $k' + 1$ elements and all subsets of $\{H_0^1, H_0^2, \dots, H_0^K\}$ with $K - k + 1$ elements. It is easily verified that these spaces are totally blocked whenever $K \geq 3$, $1 \leq k$ and $k' < K$. By Theorem 5, any strategy-proof social choice function $F : S^n \rightarrow X$ is dictatorial.¹⁸

The following result yields two further types of dictatorial domains.

- Proposition 5.1** a) *An l -cycle is totally blocked if and only if $l \neq 4$.*
b) *The permutahedron X_A is totally blocked whenever $\#X_A > 2$.*

5.2 Local Dictators

Non-dictatorial social choice functions on spaces that are not totally blocked can still be rather degenerate since they may possess “local” dictators in the following sense.

Definition (Local Dictator) A voter i is called a *local dictator* if there exists a subdomain $\mathcal{D} \subseteq \mathcal{S}$ containing at least two preferences with different peaks such that for all $(\succ_1, \dots, \succ_n) \in \mathcal{D}^n$, $F(\succ_1, \dots, \succ_n) = x_i^*$, where x_i^* is the peak of \succ_i .

As is easily verified, voting by committees possesses a local dictator if and only if there exists at least one property H and one voter i such that $\{i\}$ forms a winning coalition both in \mathcal{W}_H and \mathcal{W}_{H^c} ; in this case, i is in fact a dictator over the issue (H, H^c) . An example of a non-dictatorial domain on which all strategy-proof social choice functions necessarily involve local dictators is the single-peaked domain associated with the following graph (cf. Fig. 1f above).

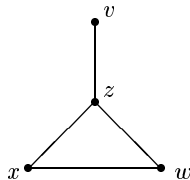

Figure 7: A domain implying local dictators

¹⁸Aswal, Chatterji and Sen (2002) prove a related impossibility result on subsets of this form (which they call “interval subsets”) for a larger preference domain.

Using the Intersection Property, one can show that any onto strategy-proof social choice rule is of the following type. Fix any $i \in N$ and $M \subseteq N$ such that $i \in M$. The final outcome is v whenever all voters in M agree on v as the best alternative. Otherwise, the final outcome is i 's most preferred alternative among $\{x, z, w\}$. Clearly, i is a local dictator. To see that any such rule is strategy-proof, note first that at any profile in which i 's peak is different from v , i evidently does not want to misreport, and other voters cannot influence the outcome. Assume thus that i 's peak is equal to v . By single-peakedness, i 's most preferred alternative among $\{x, z, w\}$ is z in this case. Hence, by construction, if any voter can influence the outcome by misreporting, she can change the outcome only from v to z or from z to v , neither of which is ever beneficial, again due to the single-peakedness.

The unavoidability of local dictators in this example follows from the fact that it contains a convex totally blocked subset (the 3-cycle $\{x, z, w\}$) due to the following result.

Proposition 5.2 *Any onto and strategy-proof $F : S^n \rightarrow X$ on a property space with a convex, totally blocked subset possesses a local dictator.*

In view of Proposition 5.1a) above, this result yields a powerful local criterion for dictatorship in graphic property spaces, namely the existence of a convex l -cycle with $l \neq 4$ in the corresponding graph (cf. Fig. 1f, 1g, 1h and 1i). Note that also the graph in Fig. 1d contains a 6-cycle, the six ‘‘outer’’ points, but these do not form a convex set.

6 The Possibility-Impossibility Frontier: Anonymity

In this section, we characterize the class of all single-peaked domains that admit anonymous strategy-proof social choice. We begin our analysis in 6.1 with a characterization of the class of all single-peaked domains that admit strategy-proof ‘‘unanimity rules.’’ Their study motivates the central new geometric concepts needed in the remainder of the paper (those of a ‘‘median point’’ and a ‘‘quasi-median space’’), and leads to an ‘‘almost’’-characterization of the domains that give rise to anonymous strategy-proof social choice functions. The desired exact characterization of these domains is provided in Subsection 6.2.

6.1 Unanimity Rules

A natural and simple way to try to define anonymous social choice functions on property spaces is by means of ‘‘unanimity rules.’’ These are defined as follows.

Definition (Unanimity Rule) Say that a social choice function $F : \mathcal{D}^n \rightarrow X$ is a *unanimity rule* if there exists $\hat{x} \in X$ such that

$$F(\succ_1, \dots, \succ_n) = \hat{x} \text{ whenever } \hat{x} \in \{x_1^*, \dots, x_n^*\}, \quad (6.1)$$

where x_i^* denotes the peak of \succ_i . Clearly, a state \hat{x} satisfying (6.1) is uniquely determined and is referred to as the *status quo*.

Thus, a unanimity rule prescribes the choice of the status quo as soon as at least one voter endorses that outcome. In general, a unanimity rule is not fully determined by

(6.1) since it does not specify a social choice if none of the peaks coincides with the status quo. However, among all unanimity rules with a given status quo \hat{x} there is only one that has the structure of voting by committees. Denote by $F_{\hat{x}}$ voting by committees with $\mathcal{W}_H = 2^N \setminus \{\emptyset\}$ for all $H \ni \hat{x}$ and $\mathcal{W}_H = \{N\}$ for all $H \not\ni \hat{x}$.

Fact 6.1 *Voting by committees is a unanimity rule if and only if it is of the form $F_{\hat{x}}$ for some $\hat{x} \in X$.*

When is $F_{\hat{x}}$ consistent? A simple necessary condition is that any triple of alternatives containing the status quo \hat{x} must admit a median. To see this, consider two alternatives y, z and two voters with peaks at y and z , respectively. By Lemma A.2 in the appendix, the outcome under $F_{\hat{x}}$ must lie between the two peaks, i.e. $F_{\hat{x}}(\succ_1, \succ_2) \in [y, z]$. Moreover $F_{\hat{x}}(\succ_1, \succ_2) \in [\hat{x}, y]$ since no property H with $\{\hat{x}, y\} \cap H = \emptyset$ gets unanimous support, and by the same argument, $F_{\hat{x}}(\succ_1, \succ_2) \in [\hat{x}, z]$. In other words, the triple $\{\hat{x}, y, z\}$ must admit a median, namely $F_{\hat{x}}(\succ_1, \succ_2)$.

Definition (Median Point) An element $x \in X$ is called a *median point* in (X, \mathcal{H}) if, for any y, z , there exists a (unique) element $m(x, y, z) \in X$ that is between any pair of $\{x, y, z\}$. The set of median points is denoted by $M(X)$.

Definition (Quasi-Median Space) A property space (X, \mathcal{H}) is called a *quasi-median space* if $M(X) \neq \emptyset$

Obviously, a quasi-median space is a median space if and only if *every* element is a median point. It can be shown that $M(X)$ is always median stable (see Nehring and Puppe (2002b)).

Proposition 6.1 *$F_{\hat{x}}$ is consistent if and only if $\hat{x} \in M(X)$. If $F_{\hat{x}}$ is consistent, $F_{\hat{x}}(\succ_1, \dots, \succ_n)$ is the unique element in the convex hull $Co\{x_1^*, \dots, x_n^*\}$ that is between \hat{x} and any x_i^* , where x_i^* denotes the peak of \succ_i .*

To illustrate, consider again the two subsets of the hypercube in Figure 6 above. As is easily verified, the 6-cycle in Fig. 6a has no median points. By comparison, the seven-point subset in Fig. 6b has the four median points x_2, x_4, x_6 and x_7 . By Proposition 6.1, it therefore admits four different strategy-proof unanimity rules, each corresponding to one of the four median points as the status quo. Note that, while the space is a quasi-median space, it is not a median space since the triple x_1, x_3, x_5 does not admit a median.

The following proposition summarizes and adds a characterization in terms of the conditional entailment relation \geq introduced in Section 5 above.

Proposition 6.2 *The following conditions are equivalent.*

- (i) (X, \mathcal{H}) admits a strategy-proof and onto unanimity rule $F : \mathcal{S}^n \rightarrow X$.
- (ii) (X, \mathcal{H}) is a quasi-median space.
- (iii) For no $H \in \mathcal{H}$, $H \equiv H^c$ (all $H \in \mathcal{H}$ are “unblocked”).

The intuition behind the equivalence “(i) \Leftrightarrow (ii)” is particularly transparent in the case of two voters, in which case the unanimity rules exhaust the class of all anonymous strategy-proof social choice functions $F : \mathcal{S}^2 \rightarrow X$. All such rules can be described as follows: choose any median point $\hat{x} \in M(X)$ and set $F(\succ_1, \succ_2) = m(\hat{x}, x_1^*, x_2^*)$, where x_i^* is the peak of \succ_i . Thus, the final outcome is the median of \hat{x} and the two voters’

peaks; following Moulin (1980), the “status quo” \hat{x} can also be interpreted as the peak of a “phantom voter.”¹⁹

6.2 Anonymous Strategy-Proof Social Choice

Unanimity rules seem to be the natural way to establish the existence of anonymous choice rules on property spaces. One might therefore conjecture that the domains that admit anonymous strategy-proof social choice are exactly those that admit strategy-proof unanimity rules. However, the absence of a median point does not force violations of anonymity, as shown by the following example.

Example 9 (Voting by Quota without Median Points) Consider the subspace $X \subseteq \{0, 1\}^5$ shown in the following figure.

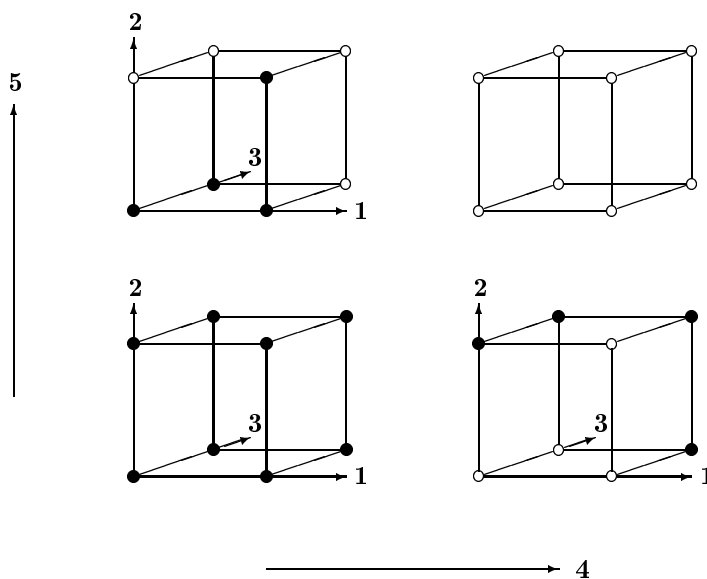

Figure 8: Anonymity and strategy-proofness without median points

This space is characterized by the following critical families: $\mathcal{G}_1 = \{H_1^1, H_0^3, H_1^4\}$, $\mathcal{G}_2 = \{H_1^1, H_1^3, H_1^5\}$, $\mathcal{G}_3 = \{H_0^1, H_0^2, H_1^4\}$, $\mathcal{G}_4 = \{H_0^1, H_1^2, H_1^5\}$, $\mathcal{G}_5 = \{H_0^2, H_0^3, H_1^4\}$, $\mathcal{G}_6 = \{H_1^2, H_1^3, H_1^5\}$ and $\mathcal{G}_7 = \{H_1^4, H_1^5\}$.²⁰ As is easily verified, one has $H_0^k \equiv H_1^k$ for $k = 1, 2, 3$. Since $H_1^k = (H_0^k)^c$, this implies by Proposition 6.2(iii) that the underlying space is not a quasi-median space. However, despite the fact that $M(X) = \emptyset$, there exists an anonymous social choice rule. Indeed, for an odd number n of voters, define the following quotas, where q_1^k denotes the quota corresponding to H_1^k : $q_1^1 = q_1^2 = q_1^3 = \frac{1}{2}$

¹⁹A related result in the two voter case has already been obtained by Bogomolnaia (1999).

²⁰In Fig. 8, the first three coordinates of an element of X are determined within the four small cubes. The two cubes to the left correspond to the basic property H_0^4 (have a “0” in the fourth coordinate), whereas the two cubes to the right correspond to H_1^4 (have a “1” in the fourth coordinate). Similarly, the two bottom cubes correspond to H_0^5 , and the two top cubes to H_1^5 . Missing elements are indicated by blank circles. Thus, for instance, the criticality of $\{H_1^4, H_1^5\} = \mathcal{G}_7$ reflects the fact that the top-right cube contains no elements of X .

and $q_1^4 = q_1^5 = 1$. By (3.4), this quota rule is consistent.

Given a property space (X, \mathcal{H}) , denote for each $G \in \mathcal{H}$, $\mathcal{H}_{\equiv G} := \{H \in \mathcal{H} : H \equiv G\}$.

Definition (Quasi-Unblockedness) Say that a basic property $G \in \mathcal{H}$ is *quasi-unblocked* if for any critical family \mathcal{G} , $\#(\mathcal{H}_{\equiv G} \cap \mathcal{G}) \leq 2$, whenever $G \equiv G^c$.

Definition (Quasi-Quasi-Median Space) Say that a property space (X, \mathcal{H}) is a *quasi-quasi-median space* if every $H \in \mathcal{H}$ is quasi-unblocked.

Theorem 6 *The following conditions are equivalent.*

- (i) (X, \mathcal{H}) admits an anonymous, strategy-proof and onto scf $F : S^n \rightarrow X$.
- (ii) (X, \mathcal{H}) admits a strategy-proof and onto scf $F : S^n \rightarrow X$ with no local dictator.
- (iii) (X, \mathcal{H}) is a quasi-quasi-median space.

Moreover, if $G \in \mathcal{H}$ is not quasi-unblocked, then any strategy-proof and onto social choice function $F : S^n \rightarrow X$ is fully dictatorial on $\mathcal{H}_{\equiv G}$.

The proof of Theorem 6 provided in the appendix shows that all anonymous and strategy-proof social choice functions $F : S^n \rightarrow X$ outside the class of quasi-median spaces have the following very special structure. There exists a proper non-empty subfamily $\mathcal{H}_0 \subseteq \mathcal{H}$, closed under taking complements, such that F takes the form of majority voting on \mathcal{H}_0 and the form of a unanimity rule on a non-empty subfamily of $\mathcal{H} \setminus \mathcal{H}_0$. Thus, all anonymous rules that are not defined on quasi-median spaces must be similar to the one described in Example 9, which represents the simplest example that one can construct. This shows that outside the class of quasi-median spaces there is very limited room for non-dictatorial and non-manipulable social choice.

7 The Possibility-Impossibility Frontier: No Veto Power

We have shown that quasi-median spaces enable non-degenerate strategy-proof social choice via unanimity rules. However, unanimity rules represent an extreme departure from neutrality: some alternatives (resp. properties) are chosen on the basis of a single supporting voter, while others require the support of all voters. A domain that forces any anonymous and strategy-proof social choice function to exhibit such extreme form of non-neutrality must clearly be viewed as very restrictive. Thus, in this section we shall determine those domains that admit “qualified majority voting by properties” where the majority-quota for some properties may exceed one half but is always strictly less than one.²¹

In more general terms that do not presuppose anonymity, we shall characterize those domains that admit strategy-proof social choice satisfying the following condition of “no veto power.”

Definition (No Veto Power) Say that F satisfies *no veto power* if $F(\succ_1, \dots, \succ_n) = x$ whenever at least $n - 1$ voters have their peak at x .

²¹In Nehring and Puppe (2002a) it is shown that ex-post efficient strategy-proof social choice on single-peaked domains requires a weak neutrality condition; heuristically, this further strengthens the interest in domains that admit at least “minimally neutral” strategy-proof social choice functions.

Fact 7.1 *Voting by committees satisfies no veto power if and only if no single voter ever forms a winning coalition, i.e. $\{i\} \notin \mathcal{W}_H$ for all $i \in N$ and all $H \in \mathcal{H}$.*

Note that, under voting by committees, absence of veto power (over any alternative) entails by Fact 7.1 the absence of veto power over any *issue*, a substantially stronger property.

For the geometric characterization of the single-peaked domains that give rise to strategy-proof social choice without veto power we need some additional concepts. Given a property space (X, \mathcal{H}) , say that two elements x and y are *immediate neighbours* if they differ in exactly one issue, i.e. if there exists exactly one basic property $H \in \mathcal{H}$ such that $x \in H$ and $y \in H^c$. For instance, in Figure 6a each point has exactly two immediate neighbours, while in Figure 6b, the points x_2, x_4, x_6 and x_7 have three immediate neighbours. A subset $Y \subseteq X$ will be called *connected* if, for any pair $x, y \in Y$ with $x \neq y$, there exist $z_1, \dots, z_l \in Y$ such that $z_1 = x, z_l = y$, and z_{i+1} is an immediate neighbour of z_i for all $i = 1, \dots, l - 1$ (for illustration, see Figure 9 below).

For any family $\mathcal{F} \subseteq \mathcal{H}$ with $H \in \mathcal{F} \Rightarrow H^c \in \mathcal{F}$, define an equivalence relation on X by $x \approx_{\mathcal{F}} y \Leftrightarrow [\text{for all } H \in \mathcal{F} : H \ni x \Leftrightarrow H \ni y]$, and denote by X/\mathcal{F} the induced partition of X into equivalence classes. Thus, X/\mathcal{F} results from X by identifying elements that differ only in “non- \mathcal{F} issues;” in particular, note that $X = X/\mathcal{H}$. The property space $(X/\mathcal{F}, \mathcal{F})$ is referred to as the *projected space* induced by X and \mathcal{F} .²²

To illustrate, consider a space (X, \mathcal{H}) embedded in a hypercube, so that each issue (H, H^c) corresponds to one coordinate and the family \mathcal{F} to a particular set of coordinates. Then, $(X/\mathcal{F}, \mathcal{F})$ is simply the projection of (X, \mathcal{H}) to the “ \mathcal{F} -coordinates.” For instance, in Figure 9a below, the projection of X to the first two coordinates (corresponding to $\mathcal{F} = \{H_0^1, H_1^1, H_0^2, H_1^2\}$) is isomorphic to a 2-dimensional hypercube. By contrast, the projection to coordinates 1 and 3 (as well as the projection to coordinates 2 and 3) is isomorphic to a three-point line.

Definition (Cohesive Quasi-Median Space) A property space (X, \mathcal{H}) is called a *cohesive quasi-median space* if, for any family $\mathcal{F} \subseteq \mathcal{H}$, the set of median points $M(X/\mathcal{F})$ of the induced projected space is connected and has at least two elements.

The following figure shows two quasi-median spaces neither of which is cohesive. In Fig. 9a there is only one median point (the encircled alternative y). By contrast, in Fig. 9b there are the two median points y and y' ; however, here the set $M(X) = \{y, y'\}$ is not connected (cf. Fig. 1e above).

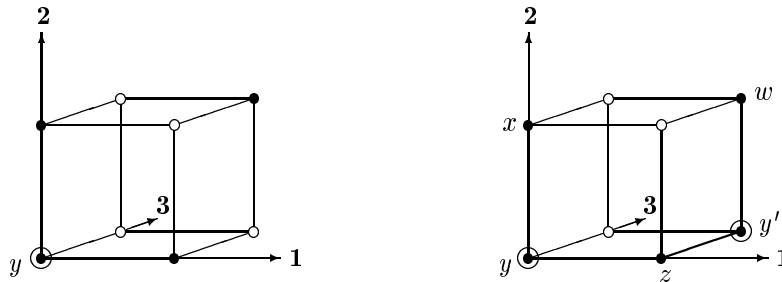

9a: A non-connected space

9b: A connected space

Figure 9: Two quasi-median spaces

²²With slight abuse of notation, $H \in \mathcal{F}$ is identified with the corresponding subset of X/\mathcal{F} .

Cohesive quasi-median spaces have a rich geometric structure. In particular, any cohesive quasi-median space is a graphic property space, and its graph is bipartite, that is: all cycles have even length. In our context, the appropriateness of the notion of cohesive quasi-median space derives from the following central result.

Theorem 7 *The following conditions are equivalent.*

- (i) (X, \mathcal{H}) admits an onto strategy-proof scf $F : S^n \rightarrow X$ with no veto power.
- (ii) \geq is antisymmetric, i.e. $[H \geq G \text{ and } G \geq H] \Rightarrow H = G$.
- (iii) (X, \mathcal{H}) is a cohesive quasi-median space.

The necessity of the antisymmetry of \geq for no veto power follows by arguments similar to those used in Section 5 above. The idea underlying the proof of the converse statement is as follows. By a modified application of Szpilrajn's theorem, the conditional entailment relation \geq can be extended to a complementation-adapted linear ordering \geq^* of \mathcal{H} . A consistent committee structure can then be defined by choosing quotas $q_H < 1$ as an appropriate monotone transformation of the rank of H in the ordering \geq^* . By constructing a social choice function that takes the form of voting by quota, the proof thus in effect shows that any space with an antisymmetric conditional entailment relation admits an *anonymous* strategy-proof social choice function without veto power. A nice feature of Theorem 7 is the existence of a crisp geometric characterization of the antisymmetry property of the conditional entailment relation, and thus of no veto power. By contrast, non-dictatorship and anonymity do not seem to have comparably simple geometric characterizations.

Theorem 7 shows that of all examples outside the class of median spaces that we have given so far, only the seven-point graph in Fig. 6b admits strategy-proof social choice with no veto power under single-peakedness; indeed, the geometric condition that defines cohesive quasi-median spaces is easily verified in that example. Are there other instances of cohesive quasi-median spaces? The following class yields many further examples.

Example 10 (Centered subspaces of \mathbf{Z}^K) Denote by \mathbf{Z} the set of integers, and consider the K -fold cartesian product \mathbf{Z}^K endowed with the product betweenness induced by the line betweenness in each coordinate (cf. Ex. 4 above). A (finite) subspace $X \subseteq \mathbf{Z}^K$ will be called *centered* if there exists $\tilde{x} \in X$ such that for all $x \in X$, $[\tilde{x}, x] \subseteq X$, i.e. such that all segments between \tilde{x} and any other element of X are contained in X . Figure 10 below shows a typical example. In the figure, the center \tilde{x} is the origin $(0, 0, 0)$. As is easily verified, the median points are the encircled points on the axes emanating from the center \tilde{x} . In particular, the depicted subset is not a median space.

In centered subspaces of \mathbf{Z}^K , one can verify directly the strategy-proofness and, using the Intersection Property, the consistency of the anonymous rule given by the quotas $q_H = \frac{1}{K}$ if $H \ni \tilde{x}$, and $q_H = 1 - \frac{1}{K}$ if $H \not\ni \tilde{x}$. This rule exhibits no veto power whenever $n > K$. In particular, by Theorem 7, any centered subspace of \mathbf{Z}^K is a cohesive quasi-median space.

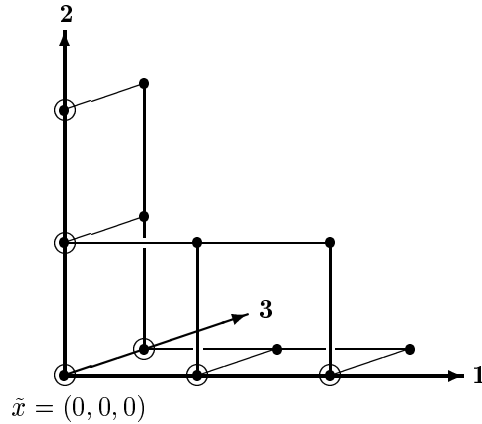

Figure 10: A centered subspace of \mathbf{Z}^3

As a concrete example, consider the elements of the hypercube as sets of candidates (“boards”) with a 1 in coordinate k standing for “candidate k is on the board.” Suppose that there are a number of representation requirements to be satisfied, such as “at least one women should be on the board,” or “at least two members of the board should be social choice theorists,” etc. Furthermore, assume that the board of *all* candidates (the point $(1, \dots, 1)$ in the hypercube) satisfies all these requirements. Then, the subset of all feasible boards (those that satisfy the representation requirements) is a centered subset of $\{0, 1\}^K$ with center $\tilde{x} = (1, \dots, 1)$. As can be inferred from a comparison with the dictatorial domains in Example 8 above, the key feature here is that all representation requirements are *lower* bounds. Also note the existence of social states that are conceivable but not feasible (e.g. a board without social choice theorists) in this particular example. Single-peakedness of preferences over feasible boards is naturally interpreted as separability of preferences over conceivable boards combined with the assumption that the preferences of all voters are consistent with the representation requirements in the sense that all peaks are feasible. The latter assumption is clearly restrictive.²³ By contrast, in the hypercube embedding used repeatedly above, the points outside the domain are purely mathematical constructs illustrating the structure of the property space; they have no conceptual reality, in particular, they are not objects of preference. Hence, the the restrictiveness issue just pointed out does not arise under this domain interpretation. For instance, if one embeds a line in the hypercube one obtains fictitious points having the contradictory properties of “being to the left” and “being to the right” of some given point.

²³For a study of feasibility constraints without that assumption, see Barberá, Massò and Neme (2001).

8 Conclusion

In this paper, we have defined a general notion of single-peakedness based on abstract betweenness relations. We have shown that a social choice function is strategy-proof on a single-peaked domain if and only if it takes the form of voting by committees satisfying the Intersection Property. On the basis of this characterization, we have classified all single-peaked domains in terms of the extent to which they enable well-behaved strategy-proof social choice. Table 1 below summarizes our main results. Note the two blank entries in the right column of the table. Indeed, we do not know whether there exists a simple geometric characterization of non-dictatorship. For the condition of anonymity, on the other hand, the quasi-median property (i.e. the existence of at least one median point) yields an “almost”-characterization, as we have argued in Section 6 above.

Property of Enabled Social Choice Function	Characterization in terms of Conditional Entailment	Geometric Characterization
no dictatorship	$H \not\geq G$ for some H, G (“not totally blocked”)	—
anonymity	“all H quasi-unblocked”	—
unanimity	$H \not\geq H^c$ for all H (“all H unblocked”)	quasi-median space
no veto power	\geq antisymmetric	cohesive quasi-median space
neutrality without dictatorship	$H \geq G \Leftrightarrow H \subseteq G$ (coincides with subsethood)	median space

Table 1: Summary of the main characterization results

An important question left open by the present analysis concerns the efficiency properties of strategy-proof social choice. This is addressed in the companion paper Nehring and Puppe (2002a), where we characterize the class of all strategy-proof and efficient social choice functions on single-peaked domains. In another paper, Nehring and Puppe (2002b), we study in more detail the structure of the class of strategy-proof social choice functions that exist on a given quasi-median space.

Appendix: Proofs

Proof of Proposition 2.1 Let \succ be single-peaked on (X, \mathcal{H}) with peak x^* ; define $\mathcal{H}_g := \{H \in \mathcal{H} : x^* \in H\}$ and $\mathcal{H}_b := \{H \in \mathcal{H} : x^* \notin H\}$. Obviously, this partition of \mathcal{H} satisfies all required properties.

Conversely, let the partition $\mathcal{H} = \mathcal{H}_g \cup \mathcal{H}_b$ satisfy (i) and (ii). It is straightforward to verify that \succ is single-peaked with peak x^* .

Proof of Fact 3.1 Suppose that $x \in f_{\mathcal{W}}(\xi)$ and consider any $y \neq x$. By condition H3, there exists $H \in \mathcal{H}$ such that $x \in H$ and $y \in H^c$. By definition of $f_{\mathcal{W}}$, $\{i : \xi_i \in H\} \in \mathcal{W}_H$. By CS1, $\{i : \xi_i \in H\}^c = \{i : \xi_i \in H^c\} \notin \mathcal{W}_{H^c}$, hence by definition, $y \notin f_{\mathcal{W}}(\xi)$.

Proof of Proposition 3.1 Since committees are by definition closed under taking supersets, voting by committees is monotone in properties by (3.3). Furthermore, voting by committees is clearly onto since it satisfies unanimity.

Conversely, let $f : X^n \rightarrow X$ be onto and monotone in properties. For any $H \in \mathcal{H}$, define

$$\mathcal{W}_H := \{W \subseteq N : \exists \xi \text{ such that } \{i : \xi_i \in H\} = W \text{ and } f(\xi) \in H\}.$$

Note that by monotonicity of f , the definition of \mathcal{W}_H does not depend on the choice of ξ . Since f is onto, \mathcal{W}_H is non-empty. We verify that \mathcal{W}_H is closed under taking supersets. Hence, suppose that $W \in \mathcal{W}_H$ and $W' \supseteq W$. Choose ξ such that $W = \{i : \xi_i \in H\}$ and $f(\xi) \in H$. Define ξ' as follows: $\xi_i = \xi_i$ whenever $i \in W$ or $i \in N \setminus W'$, and $\xi'_j \in H$ if $j \in W' \setminus W$. Then, $W' = \{i : \xi'_i \in H\}$ and, by monotonicity in properties, $f(\xi') \in H$. Hence, by definition, $W' \in \mathcal{W}_H$.

Next, we verify properties CS1 and CS2. It is easily seen that $W^c \notin \mathcal{W}_{H^c}$ implies $W \in \mathcal{W}_H$. To verify the converse implication, assume by way of contradiction that $W \in \mathcal{W}_H$ and $W^c \in \mathcal{W}_{H^c}$. Choose ξ with $\{i : \xi_i \in H\} = W$ and $f(\xi) \in H$, and ξ' with $\{i : \xi'_i \in H^c\} = W^c$ and $f(\xi') \in H^c$. Consider ξ'' defined by $\xi''_i = \xi_i$ for $i \in W$ and $\xi''_i = \xi'_i$ for $i \in W^c$. By monotonicity in properties, $f(\xi'') \in H$ and $f(\xi'') \in H^c$, a contradiction. This shows that \mathcal{W} satisfies CS1. To verify CS2, let $H \subseteq H'$ and $W \in \mathcal{W}_H$. Choose ξ such that $\{i : \xi_i \in H\} = W$ and $f(\xi) \in H$. Consider ξ' with $\xi'_i = \xi_i$ for $i \in W$ and $\xi'_i \in H'^c$ for $i \notin W$. By monotonicity in properties, $f(\xi') \in H$, hence $f(\xi') \in H'$, and thus $W = \{i : \xi'_i \in H'\} \in \mathcal{W}_{H'}$.

The proof is completed by noting that $f = f_{\mathcal{W}}$. Indeed, by definition of \mathcal{W} , one clearly has $f(\xi) \in f_{\mathcal{W}}(\xi)$, but $f_{\mathcal{W}}$ is single-valued by Fact 3.1.

Proof of Proposition 3.2 Suppose $f : X^n \rightarrow X$ is monotone in properties. Consider an individual j with true peak ξ_j who reports $\hat{\xi}_j$. Let $H \in \mathcal{H}$ be any basic property such that $\xi_j \in H$ and $f(\hat{\xi}_j, \xi_{-j}) \in H$. Clearly, $\{i : (\hat{\xi}_j, \xi_{-j})_i \in H\} \subseteq \{i : \xi_i \in H\}$, hence by monotonicity in properties $f(\xi) \in H$. This shows that $f(\xi) \in [\xi_j, f(\hat{\xi}_j, \xi_{-j})]$, i.e. $f(\xi)$ is between the true peak ξ_j and the outcome $f(\hat{\xi}_j, \xi_{-j})$. By single-peakedness, this implies that $f(\xi) \succ_j f(\hat{\xi}_j, \xi_{-j})$ whenever $f(\xi) \neq f(\hat{\xi}_j, \xi_{-j})$.

Conversely, suppose that f is not monotone in properties; then there exist ξ, ξ' and H such that $W := \{i : \xi_i \in H\} \subseteq W' := \{i : \xi'_i \in H\}$, $f(\xi) \in H$ but $f(\xi') \in H^c$. Without loss of generality, we may assume that $W' = W \cup \{j\}$ for some individual $j \notin W$. Let \succ_j be a single-peaked preference with top ξ'_j such that $x \succ_j y$ whenever $x \in H$ and $y \in H^c$. The existence of such a preference ordering is easily established. Clearly, if \succ_j is the true preference of j , this voter will benefit from reporting ξ_j . Hence, F is not strategy-proof.

Proof of Proposition 3.3 The proof consists in showing how Proposition 2 of Barberá, Massò and Neme (1997) can be translated to the present framework. Their result shows that any strategy-proof social choice function \hat{F} defined on the domain of all single-peaked linear orderings with unrestricted peaks in some subset Y of the hypercube satisfies peaks only, provided that Y contains the range of \hat{F} . We first consider the case of all single-peaked linear orderings, and show then how the general case results. For $Y \subseteq \{0, 1\}^K$, denote by $\mathcal{LS}_{\{0,1\}^K}^Y$ the set of all linear orderings on the hypercube $\{0, 1\}^K$ that are single-peaked with respect to the hypercube-betweenness and that have their peak in Y .

Now consider, for any property space (X, \mathcal{H}) , a social choice F defined on $\mathcal{LS}_{(X, \mathcal{H})}$, the set of all single-peaked linear orderings on (X, \mathcal{H}) . By Fact 3.2, there exists an isomorphism $\phi : X \rightarrow Y \subseteq \{0, 1\}^K$, for appropriate K , such that $(x, y, z) \in T$ if and only if $\phi(y)$ is between $\phi(x)$ and $\phi(z)$ in the sense of the hypercube-betweenness.²⁴ By Proposition 2.1, a preference ordering \succ is single-peaked on (X, \mathcal{H}) if and only if its image under ϕ is single-peaked on Y (with respect to the hypercube betweenness on Y). Denote by \mathcal{LS}_Y the set of all single-peaked linear orderings on Y . The function F can thus be viewed as a function $F : [\mathcal{LS}_Y]^n \rightarrow Y$. To F associate a function $\hat{F} : [\mathcal{LS}_{\{0,1\}^K}^Y]^n \rightarrow \{0, 1\}^K$ with $\text{range}\hat{F} = Y$ as follows.

Lemma A.1 *Denote by T^h the hypercube betweenness. Let $\succ \in \mathcal{LS}_Y$, i.e. let \succ be single-peaked with respect to the induced betweenness $T^h|_Y$. Then there exists an extension \succ^Y of \succ such that $\succ^Y \in \mathcal{LS}_{\{0,1\}^K}^Y$, i.e. \succ^Y is defined on $\{0, 1\}^K$, has its peak in Y and is single-peaked with respect to T^h .*

Proof of Lemma A.1 Let $x^* \in Y$ be the peak of \succ , furthermore, let $T_{x^*}^h$ be the partial order on the hypercube $\{0, 1\}^K$ defined by $yT_{x^*}^h z \Leftrightarrow (x^*, y, z) \in T^h$. Consider the binary relation $Q := \succ \cup T_{x^*}^h$. Since \succ extends $(T_{x^*}^h)|_Y$ on Y , Q is easily shown to be acyclic. Hence, the transitive closure \hat{Q} of Q is a partial order on X . By Szpilrajn's well-known extension theorem, there exists a linear extension \succ^Y of \hat{Q} . Clearly, \succ^Y has its peak at $x^* \in Y$ and is single-peaked on $\{0, 1\}^K$ since it extends $T_{x^*}^h$.

Proof of Proposition 3.3 (cont.) Define $\hat{F}(\succ_1^Y, \dots, \succ_n^Y) := F(\succ_1^Y|_Y, \dots, \succ_n^Y|_Y)$, where $\succ_i^Y|_Y$ is the restriction of \succ_i^Y to Y . Using Lemma A.1 it is easily verified that (i) $\text{range}\hat{F} = \text{range}F = Y$ (since F satisfies voter sovereignty), and (ii) \hat{F} is strategy-proof if and only if F is strategy-proof. By Barberá, Massò and Neme (1997, Prop. 2), \hat{F} satisfies peaks only, therefore F must also satisfy peaks only.

So far, we have shown that any strategy-proof social choice function $F : \mathcal{LS}^n \rightarrow X$ that satisfies voter sovereignty satisfies peaks only. We now prove that this holds for any domain $\prod_{i=1}^n \mathcal{D}_i$ with $\mathcal{LS}^n \subseteq \prod_i \mathcal{D}_i \subseteq \mathcal{S}^n$. Consider for some voter j a preference $\succ' \in \mathcal{S} \setminus \mathcal{D}_j$ and the domain $\mathcal{D}_0 := (\mathcal{D}_j \cup \{\succ'\}) \times \prod_{i \neq j} \mathcal{D}_i$. We show by induction that, if $F : \mathcal{D}_0 \rightarrow X$ is strategy-proof, then it satisfies peaks only. Suppose, by way of contradiction, that F does not satisfy peaks only, but that, by the induction hypothesis, F restricted to $\prod_i \mathcal{D}_i$ does. Then, there exists a profile $(\succ_1, \dots, \succ_n) \in \prod_i \mathcal{D}_i$ such that \succ_j has the same peak as \succ' and such that $y := F(\succ_{-j}, \succ') \neq F(\succ_1, \dots, \succ_n) =: z$. By the strategy-proofness of F , we must have (not $z \succ' y$). By Szpilrajn's extension theorem, there exists a linear extension \succ^* of \succ' with $y \succ^* z$. By the single-peakedness of \succ' , the linear extension \succ^* is also single-peaked with the same peak. By induction

²⁴Note that different families \mathcal{H} correspond to different subsets Y of the hypercube even for the same underlying set X .

hypothesis, we have peaks only on $\prod_i \mathcal{D}_i$, hence $F(\succ_{-j}, \succ^*) = F(\succ_{-j}, \succ_j) = z$. But then a voter j with true preference \succ^* can benefit from reporting \succ' , which contradicts the strategy-proofness of F .

For the proof of Proposition 3.4, we need the following lemma.

Lemma A.2 *For all \mathcal{W} and all $\xi \in X^n$, $f_{\mathcal{W}}(\xi) \in Co\{\xi_i : i \in N\}$.*

Proof of Lemma A.2 Let $Co\{\xi_i : i \in N\} = \cap \mathcal{H}'$ for an appropriate family $\mathcal{H}' \subseteq \mathcal{H}$. For any $H \in \mathcal{H}'$, one has $\{i : \xi_i \in H\} = N$, and hence $\{i : \xi_i \in H\} \in \mathcal{W}_H$. By (3.3), $f_{\mathcal{W}}(\xi) \in H$, hence the conclusion.

Proof of Proposition 3.4 We only show part a); from this, part b) is immediate in view of Fact 3.3. Thus, let $F_{\mathcal{W}}$ be neutral, and consider $H, H' \in \mathcal{H}$. We show that $\mathcal{W}_H \subseteq \mathcal{W}_{H'}$. Take any $W \in \mathcal{W}_H$ and choose $x \in H$ and $y \in H^c$ such that the segment $[x, y]$ is inclusion minimal. Using the transitivity condition T3, it is easily seen that $[x, y] = \{x, y\}$, i.e. there is no other element between x and y . Similarly, choose $x' \in H'$ and $y' \in (H')^c$ such that $[x', y'] = \{x', y'\}$. Now consider the following four single-peaked preferences: \succ^x having x as its top element and y as the second best, \succ^y with y as top and x as second best element, $\succ^{x'}$ with x' as top and y' as second best element, and $\succ^{y'}$ with y' as top and x' as second best element. Let $\sigma : X \rightarrow X$ be a permutation such that $w \succ^x z \Leftrightarrow \sigma(w) \succ^{x'} \sigma(z)$ and $w \succ^y z \Leftrightarrow \sigma(w) \succ^{y'} \sigma(z)$, for all w, z . In particular, $\sigma(x) = x'$ and $\sigma(y) = y'$. Denote by $(\succ^x; W, \succ^y; W^c)$ the simple profile in which all voters in W have the preference \succ^x and all others have the preference \succ^y . Since $W \in \mathcal{W}_H$, we must have $F_{\mathcal{W}}(\succ^x; W, \succ^y; W^c) \in H$ and in fact $F_{\mathcal{W}}(\succ^x; W, \succ^y; W^c) = x$, since by Lemma A.2, $F_{\mathcal{W}}(\succ^x; W, \succ^y; W^c) \in [x, y]$. By neutrality, $F_{\mathcal{W}}(\succ^{x'}; W, \succ^{y'}; W^c) = \sigma(x) = x'$, which implies $W \in \mathcal{W}_{H'}$ by (3.3).

The converse implication follows immediately from the from the following lemma.

Lemma A.3 *Let $x \neq y$, and suppose that $\mathcal{W}_H = \mathcal{W}_0$ for some \mathcal{W}_0 and all $H \in \mathcal{H}$. Then $F_{\mathcal{W}}(\succ^x; W, \succ^y; W^c) = x$ if and only if $W \in \mathcal{W}_0$.*

Proof of Lemma A.3 Clearly, if $F_{\mathcal{W}}(\succ^x; W, \succ^y; W^c) = x$, then W must be a winning coalition; indeed, otherwise W^c would be winning and could therefore enforce a basic property $H \ni y$ with $x \notin H$.

Conversely, suppose that $W \in \mathcal{W}_0$. Since $\mathcal{W}_H = \mathcal{W}_0$ for all $H \in \mathcal{H}$, W is winning for any basic property. In particular, W enforces all basic property H that contain x . But their intersection contains the single point x by H3.

Proof of Proposition 3.5 Suppose $f_{\mathcal{W}}$ is consistent, and let $\mathcal{G} = \{G_1, \dots, G_l\}$ be a critical family. For $j = 1, \dots, l$, consider any selection $W_j \in \mathcal{W}_{G_j}$. We will show $\cap_{j=1}^l W_j \neq \emptyset$ by a contradiction argument. Thus, assume that $\cap_{j=1}^l W_j = \emptyset$. Then, for all $i \in N$, there exists j_i such that $i \notin W_{j_i}$. For each i , pick an element $\xi_i \in G_{j_i}^c \cap (\cap_{j \neq j_i} G_j) = \cap_{j \neq j_i} G_j$ (observe that the latter set is non-empty by definition of a critical family). By construction, if $i \in W_j$, then $j \neq j_i$, hence $\xi_i \in G_j$. This shows that, for all j , $W_j \subseteq \{i : \xi_i \in G_j\}$. Therefore, $\{i : \xi_i \in G_j\} \in \mathcal{W}_{G_j}$, hence by (3.3), $f_{\mathcal{W}}(\xi_1, \dots, \xi_n) \in G_j$ for all $j = 1, \dots, l$. However, this contradicts the fact that $\{G_1, \dots, G_l\}$ is a critical family.

Conversely, suppose $f_{\mathcal{W}}$ is not consistent, i.e. for some ξ , $f_{\mathcal{W}}(\xi) = \emptyset$. By (3.2) and CS1, this implies that $\cap\{H \in \mathcal{H} : \{i : \xi_i \in H\} \in \mathcal{W}_H\} = \emptyset$. We show that $f_{\mathcal{W}}$ cannot satisfy the Intersection Property by contradiction. Thus assume $f_{\mathcal{W}}$ does satisfy the Intersection Property. Pick a critical family $\{G_1, \dots, G_l\} \subseteq \{H \in \mathcal{H} : \{i : \xi_i \in H\} \in \mathcal{W}_H\}$

\mathcal{W}_H). By the Intersection Property, $\bigcap_{j=1}^l \{i : \xi_i \in G_j\} \neq \emptyset$. Let $i_0 \in \{i : \xi_i \in G_j\}$ for all $j = 1, \dots, l$. But then $\xi_{i_0} \in G_j$ for all j , contradicting the fact that $\{G_1, \dots, G_l\}$ is a critical family.

Proof of Fact 4.1 Suppose, by way of contradiction, that x, y, z admit two distinct medians $m_1 \neq m_2$. By H3, these can be separated by a basic property H such that $m_1 \in H$ and $m_2 \in H^c$. Clearly, either H or H^c must contain at least two elements of $\{x, y, z\}$, say $\{x, y\} \subseteq H$. Since $m_2 \in [x, y]$, and since H is convex, it follows that $m_2 \in H$, a contradiction.

Proof of Proposition 4.1 The equivalence of (iv) and (ii) is immediate since a critical family with more than two elements violates the pairwise intersection property; conversely, any minimal family of basic properties violating the pairwise intersection property must contain at least three elements and is by definition a critical family.

To prove the implication “(i) \Rightarrow (ii),” take any collection $\{H_1, \dots, H_l\} \subseteq \mathcal{H}$ such that $H_k \cap H_h \neq \emptyset$ for all $k, h \in \{1, \dots, l\}$. We verify the pairwise intersection property by induction. For $l = 2$ it holds trivially; thus assume $l > 2$. Let $S := H_1 \cap \dots \cap H_{l-2}$. Choose $x \in S \cap H_{l-1}$, $y \in S \cap H_l$ and $z \in H_{l-1} \cap H_l$, the first two intersections being non-empty by induction hypothesis, the latter by assumption. Consider the median $m = m(x, y, z)$; since S is convex, $[x, y] \subseteq S$, hence $m \in S$. Similarly, $m \in H_{l-1}$ and $m \in H_l$, hence $m \in \bigcap_{k=1}^l H_k$.

The implication “(ii) \Rightarrow (iii)” is straightforward; finally, “(iii) \Rightarrow (i)” follows at once from the observation that $\{[x, y], [x, z], [y, z]\}$ is a family of convex sets with pairwise non-empty intersections.

Proof of Theorem 3 Sufficiency of the median property for universal consistency follows from Propositions 3.5 and 4.1, as shown in the main text.

Necessity can be verified as follows. Suppose that (X, \mathcal{H}) is not a median space. Specifically, let x, y, z be such that $[x, y] \cap [x, z] \cap [y, z] = \emptyset$. For odd $n \geq 3$, consider issue-by-issue majority voting, i.e. $\mathcal{W}_H = \{W : \#W > n/2\}$ for all H . Assume that voter’s peaks are distributed as evenly as possible among the three points x, y and z . Thus, for instance, if n is divisible by 3, assume that exactly one third of the peaks are at x, y and z , respectively. Then, by definition, $f_{\mathcal{W}}(\xi) \in [x, y] \cap [x, z] \cap [y, z]$; but the latter set is empty, hence issue-by-issue majority voting is not consistent. For even $n \geq 4$, the same conclusion is obtained by considering majority voting among a fixed subset of $n - 1$ individuals.

For the proof of Proposition 4.2, we use the following lemma; in its statement, $medA$ denotes the smallest median stable set that contains A (the so-called “median stabilization” of A). Lemma A.4 is a straightforward reformulation of van de Vel (1993, Lemma 6.20, p.130); therefore its proof is omitted here.

Lemma A.4 *Let (X, \mathcal{H}) be a median space, and let $A \subseteq X$. Then $x \in medA$ if and only if for each pair $H, H' \in \mathcal{H}$ with $x \in H \cap H'$ one has $A \cap H \cap H' \neq \emptyset$.*

Proof of Proposition 4.2 By Lemma A.4, it is clear that, for any median stable subset $Y \subseteq X$, the set $Y \setminus (H \cap H')$ is again median stable. To show that any median stable set has the required form, consider an arbitrary median stable subset $Y \subseteq X$, i.e. $medY = Y$. Let $X \setminus Y = \{x_1, \dots, x_r\}$. Lemma A.4 implies that for any x_j there exist H_j, H'_j with $x_j \in H_j \cap H'_j$ such that $Y \cap H_j \cap H'_j = \emptyset$. Hence, $Y = (\dots(X \setminus (H_1 \cap H'_1)) \setminus \dots) \setminus (H_r \cap H'_r)$.

The following lemma plays a key role in the proofs of the main theorems below.

Lemma A.5 *Suppose that $\{G_1, G_2, G_3\} \subseteq \mathcal{G}$ for a critical family \mathcal{G} . If $\mathcal{W}_{G_1^c} \subseteq \mathcal{W}_{G_2}$, then $\{i\} \in \mathcal{W}_{G_3^c}$ for some $i \in N$.*

Proof of Lemma A.5 Let \tilde{W}_1 be a minimal element of \mathcal{W}_{G_1} , and let $i \in \tilde{W}_1$. By CS1 and minimality of \tilde{W}_1 , one has $(\tilde{W}_1^c \cup \{i\}) \in \mathcal{W}_{G_1^c}$. By assumption, $\mathcal{W}_{G_1^c} \subseteq \mathcal{W}_{G_2}$, hence $(\tilde{W}_1^c \cup \{i\}) \in \mathcal{W}_{G_2}$. Now consider any $W_3 \in \mathcal{W}_{G_3}$. By the Intersection Property, $\bigcap_{j=1}^3 W_j \neq \emptyset$ for any selection $W_j \in \mathcal{W}_{G_j}$. In particular, $\tilde{W}_1 \cap (\tilde{W}_1^c \cup \{i\}) \cap W_3 \neq \emptyset$. Since $\tilde{W}_1 \cap (\tilde{W}_1^c \cup \{i\}) = \{i\}$, this means $i \in W_3$ for all $W_3 \in \mathcal{W}_{G_3}$. By (3.1), this implies $\{i\} \in \mathcal{W}_{G_3^c}$.

Proof of Theorem 4 As described in the main text, the proof of the first statement in the theorem consists in showing that any neutral and strategy-proof social choice function $F : \mathcal{S}^n \rightarrow X$ satisfying voter sovereignty must be dictatorial unless the underlying space (X, \mathcal{H}) is a median space. By Theorem 2, F must be voting by committees satisfying the Intersection Property; by Proposition 3.4, $\mathcal{W}_H = \mathcal{W}_0$ for some \mathcal{W}_0 and all H . If (X, \mathcal{H}) is not a median space, there exists a critical family \mathcal{G} with at least three elements (by Proposition 4.1), say $\mathcal{G} \supseteq \{G_1, G_2, G_3\}$. By Lemma A.5, $\{i\} \in \mathcal{W}_{G_3^c} = \mathcal{W}_0$; but then voter i is a dictator.

The converse statement follows from the fact that the committee structure $\mathcal{W}_H = \mathcal{W}_0$ for all $H \in \mathcal{H}$ satisfies CS2 and, by assumption, CS1; hence it satisfies the Intersection Property on a median space by Proposition 4.1.

Proof of Theorem 5 That any strategy-proof $F : \mathcal{S}^n \rightarrow X$ on a totally blocked space must be dictatorial has already been shown in the main text. We will now prove the converse statement. Let (X, \mathcal{H}) be not totally blocked. Partition \mathcal{H} as follows.

$$\begin{aligned} \mathcal{H}_0 &:= \{H \in \mathcal{H} : H \equiv H^c\}, \\ \mathcal{H}_1^+ &:= \{H \in \mathcal{H} : H > H^c\}, \\ \mathcal{H}_1^- &:= \{H \in \mathcal{H} : H^c > H\}, \\ \mathcal{H}_2 &:= \{H \in \mathcal{H} : \text{neither } H \geq H^c \text{ nor } H^c \geq H\}. \end{aligned}$$

For future reference we note the following facts about this partition of \mathcal{H} .

- Lemma A.6 a)** *For any critical family \mathcal{G} , if $G \in \mathcal{G} \cap \mathcal{H}_1^-$, then $\mathcal{G} \setminus \{G\} \subseteq \mathcal{H}_1^+$.*
b) *For any critical family \mathcal{G} , if $\mathcal{G} \cap \mathcal{H}_0 \neq \emptyset$, then $\mathcal{G} \subseteq \mathcal{H}_0 \cup \mathcal{H}_1^+$.*
c) *Take any $\tilde{H} \in \mathcal{H}_2$. Then there exists a partition of \mathcal{H}_2 into \mathcal{H}_2^- and \mathcal{H}_2^+ with $\tilde{H} \in \mathcal{H}_2^-$ such that $G \in \mathcal{H}_2^- \Leftrightarrow G^c \in \mathcal{H}_2^+$, and for no $G \in \mathcal{H}_2^-$ and $H \in \mathcal{H}_2^+$, $G \geq H$.*

Proof of Lemma A.6 a) Suppose $G \in \mathcal{G} \cap \mathcal{H}_1^-$, i.e. $G^c > G$. Consider any other $H \in \mathcal{G}$. We have $H \geq G^c > G \geq H^c$, hence $H > H^c$, i.e. $H \in \mathcal{H}_1^+$.

b) Suppose $G \in \mathcal{G} \cap \mathcal{H}_0$ and let $H \in \mathcal{G}$ be different from G . We have $H \geq G^c \equiv G \geq H^c$, hence $H \geq H^c$. But this means $H \in \mathcal{H}_0 \cup \mathcal{H}_1^+$.

c) The desired partition into $\mathcal{H}_2^- = \{G_1, \dots, G_l\}$ and $\mathcal{H}_2^+ = \{G_1^c, \dots, G_l^c\}$ will be constructed inductively. Set $G_1 = \tilde{H}$, and suppose that $\{G_1, \dots, G_r\}$, with $r < l$, is determined such that $G_j \not\geq G_k^c$ for all $j, k \in \{1, \dots, r\}$. Take any $H \in \mathcal{H}_2 \setminus \{G_1, G_1^c, \dots, G_r, G_r^c\}$ and set

$$G_{r+1} := \begin{cases} H & \text{if for no } j \in \{1, \dots, r\} : G_j \geq H^c \\ H^c & \text{if for some } j \in \{1, \dots, r\} : G_j \geq H^c \end{cases}$$

First note that $G_{r+1} \not\geq G_{r+1}^c$ since $H \in \mathcal{H}_2$. Thus, the proof is completed by showing that for no $k \in \{1, \dots, r\}$, $G_k \geq G_{r+1}^c$ (and hence, by complementation adaptedness, also not $G_{r+1} \geq G_k^c$). To verify this, suppose first that $G_{r+1} = H$; then, the claim is true by construction. Thus, suppose $G_{r+1} = H^c$; by construction, there exists $j \leq r$ with $G_j \geq H^c$, hence by complementation adaptedness also $H \geq G_j^c$. Assume, by way of contradiction, that $G_k \geq G_{r+1}^c$, i.e. $G_k \geq H$. This would imply $G_k \geq H \geq G_j^c$, in contradiction to the induction hypothesis.

Proof of Theorem 5 (cont.) If $\mathcal{H}_1^+ \cup \mathcal{H}_1^-$ is non-empty, set $\mathcal{W}_H = 2^N \setminus \{\emptyset\}$ for all $H \in \mathcal{H}_1^-$ and $\mathcal{W}_H = \{N\}$ for all $H \in \mathcal{H}_1^+$; moreover, choose a voter $i \in N$ and set $\mathcal{W}_G = \{W \subseteq N : i \in W\}$ for all other $G \in \mathcal{H}$. Clearly, the corresponding voting by committees is non-dictatorial. We show that it is consistent. By the Intersection Property, the only problematic case is when a critical family \mathcal{G} contains elements of \mathcal{H}_1^- . However, by Lemma A.6a), if $G \in \mathcal{G} \cap \mathcal{H}_1^-$, we have $\mathcal{G} \setminus \{G\} \subseteq \mathcal{H}_1^+$, in which case the Intersection Property is clearly satisfied.

Next, suppose that $\mathcal{H}_1^+ \cup \mathcal{H}_1^-$ is empty, and consider first the case in which both \mathcal{H}_0 and \mathcal{H}_2 are non-empty. By Lemma A.6b), no critical family \mathcal{G} can meet both \mathcal{H}_0 and \mathcal{H}_2 . Hence, we can specify two different dictators on \mathcal{H}_0 and \mathcal{H}_2 , respectively, by setting $\mathcal{W}_H = \{W : i \in W\}$ for all $H \in \mathcal{H}_0$ and $\mathcal{W}_G = \{W : j \in W\}$ for all $G \in \mathcal{H}_2$ with $i \neq j$. Clearly, the Intersection Property is satisfied in this case.

Now suppose that \mathcal{H}_2 is also empty, i.e. $\mathcal{H} = \mathcal{H}_0$. Since (X, \mathcal{H}) is not totally blocked, \mathcal{H} is partitioned in at least two equivalence classes with respect to the equivalence relation \equiv . Since, obviously, no critical family can meet two different equivalence classes, we can specify different dictators on different equivalence classes while satisfying the Intersection Property.

Finally, if \mathcal{H}_0 is empty, (X, \mathcal{H}) is a quasi-median space by Proposition 6.2, hence the existence of non-dictatorial strategy-proof social choice functions follows as in the proof of Proposition 6.1 below.

Proof of Proposition 5.1 a) For $l = 4$, the l -cycle is isomorphic to the 2-dimensional hypercube which is clearly not totally blocked. Thus, assume first that l is even and $l \geq 6$. For all j , denote by $H_j := \{x_j, x_{j+1}, \dots, x_{j-1+l/2}\}$, where indices are understood modulo l throughout. The family $\{H_j, H_{j-1+l/2}, H_{j-2}\}$ is a critical family. This implies $H_j \geq^0 H_{j-1}$ for all j , since $H_{j-1} = (H_{j-1+l/2})^c$. From this, the total blockedness is immediate.

Now consider l odd with $l \geq 5$ (the 3-cycle corresponds to the unrestricted domain over three alternatives which has already been shown to be totally blocked). For all j , denote by $H_j^- = \{x_j, x_{j+1}, \dots, x_{j-1+(l-1)/2}\}$ and by $H_j^+ = \{x_j, x_{j+1}, \dots, x_{j-1+(l+1)/2}\}$. Criticality of the pair $\{H_j^-, H_{j+(l-1)/2}^-\}$ implies $H_j^- \geq^0 H_{j-1}^+$ for all j . Furthermore, criticality of the family $\{H_j^+, H_{j-1+(l+1)/2}^+, H_{j+1+(l+1)/2}^-\}$ implies both $H_j^+ \geq^0 H_{j+1}^+$ and $H_j^+ \geq^0 H_j^-$ for all j . From this, the total blockedness is again immediate.

b) Consider now the permutahedron X_A . If $\#A = 3$, the permutahedron is isomorphic to the 6-cycle, the total blockedness of which has just been verified. Thus, assume $\#A \geq 4$. Total blockedness means that, for all $a, b, c, d \in A$ with $a \neq b$ and $c \neq d$,

$$H_{(a,b)} \geq H_{(c,d)} \tag{A.1}$$

(recall that $H_{(a,b)}$ corresponds to the property “ranks a above b .”). If a, b, c, d are pairwise distinct, (A.1) follows directly from the criticality of $\{H_{(c,a)}, H_{(a,b)}, H_{(b,d)}, H_{(d,c)}\}$.

Note that by transitivity of \geq , this also implies $H_{(a,b)} \geq H_{(b,a)}$. If $c = a$ and $d \neq b$, (A.1) follows from the criticality of $\{H_{(d,a)}, H_{(a,b)}, H_{(b,d)}\}$. If $d = a$ and $c \neq b$, (A.1) follows from $H_{(a,b)} \geq H_{(c,d')} \geq H_{(c,a)}$, where d' is any element not contained in $\{a, b, c\}$. The other cases are treated analogously.

Proof of Proposition 5.2 Let $F : \mathcal{S}_{(X, \mathcal{H})}^n \rightarrow X$ be onto and strategy-proof. Also, let $Y \subseteq X$ be convex such that $(Y, \mathcal{H}|_Y)$ is totally blocked. Denote by \mathcal{S}_Y the set of all single-peaked preferences on Y and by $\mathcal{S}_{(X, \mathcal{H})}^Y$ the set of all single-peaked preferences on X that have their peak in Y . Define $F_Y : [\mathcal{S}_Y]^n \rightarrow Y$ as follows. For all $\succ_i \in \mathcal{S}_Y$,

$$F_Y(\succ_1, \dots, \succ_n) := F(\succ'_1, \dots, \succ'_n),$$

where, for each i , \succ'_i is any extension of \succ_i to X such that $\succ'_i \in \mathcal{S}_{(X, \mathcal{H})}^Y$, i.e. such that \succ'_i is single-peaked on X with the same peak as \succ_i . Since F satisfies peaks only, the definition of F_Y does not depend on the choice of the extension. Clearly, F_Y is strategy-proof on \mathcal{S}_Y . Furthermore, by Theorem 1 and Lemma A.2, $F(\succ'_1, \dots, \succ'_n) \in Y$, hence the range of F_Y is indeed Y . By assumption, $(Y, \mathcal{H}|_Y)$ is totally blocked, hence F_Y is dictatorial, by Theorem 5. But this implies that F possesses a local dictator, since the restriction of F to the subdomain $\mathcal{S}_{(X, \mathcal{H})}^Y$ coincides with F_Y .

Proof of Fact 6.1 It is clear that $F_{\hat{x}}$ defines a unanimity rule. Conversely, under voting by committees, (6.1) implies $\mathcal{W}_H = \{N\}$ for any property H with $H \not\supseteq \hat{x}$; by (3.1), this determines \mathcal{W}_H for all $H \in \mathcal{H}$.

The following lemma will be used extensively in the analysis of quasi-median spaces. For any $x \in X$, denote by $\mathcal{H}_x := \{H \in \mathcal{H} : x \in H\}$.

Lemma A.7 $x \in M(X)$ if and only if for any critical family \mathcal{G} , $\#(\mathcal{H}_x \cap \mathcal{G}) \leq 1$.

Proof of Lemma A.7 Let $x \in M(X)$; we verify $\#(\mathcal{H}_x \cap \mathcal{G}) \leq 1$ by contradiction. Thus, assume that, for some critical family \mathcal{G} , $\mathcal{H}_x \cap \mathcal{G} \supseteq \{H_1, H_2\}$. Since $x \in H_1 \cap H_2$, there exists a $G \in \mathcal{G}$ different from H_1 and H_2 . By criticality, one can choose $y \in \mathcal{G} \setminus \{H_1\}$ and $z \in \mathcal{G} \setminus \{H_2\}$. By construction, $[x, y] \subseteq H_2$, $[x, z] \subseteq H_1$ and $[y, z] \subseteq \mathcal{G} \setminus \{H_1, H_2\}$. But then $[x, y] \cap [x, z] \cap [y, z] \subseteq \mathcal{G} = \emptyset$, contradicting the fact that $x \in M(X)$.

Conversely, suppose that $x \notin M(X)$, i.e. $[x, y] \cap [x, z] \cap [y, z] = \emptyset$ for some y, z . Define $\mathcal{H}_{xy} := \{H \in \mathcal{H} : \{x, y\} \subseteq H\}$, $\mathcal{H}_{xz} := \{H \in \mathcal{H} : \{x, z\} \subseteq H\}$ and $\mathcal{H}_{yz} := \{H \in \mathcal{H} : \{y, z\} \subseteq H\}$. By assumption, one has $(\cap \mathcal{H}_{xy}) \cap (\cap \mathcal{H}_{xz}) \cap (\cap \mathcal{H}_{yz}) = \emptyset$, hence $\mathcal{H}_{xy} \cup \mathcal{H}_{xz} \cup \mathcal{H}_{yz}$ contains a critical family \mathcal{G} . Any such critical family must contain H with $H \cap \{x, y, z\} = \{x, y\}$, H' with $H' \cap \{x, y, z\} = \{x, z\}$ and H'' with $H'' \cap \{x, y, z\} = \{y, z\}$. But this implies $\#(\mathcal{H}_x \cap \mathcal{G}) \geq 2$ since $x \in H \cap H'$.

Proof of Proposition 6.1 Let $F_{\hat{x}}$ be consistent and consider $\mathcal{H}_{\hat{x}}$, the family of all properties possessed by \hat{x} . Since $\mathcal{W}_H = 2^N \setminus \{\emptyset\}$ for all $H \in \mathcal{H}_{\hat{x}}$, the Intersection Property implies that $\#(\mathcal{H}_{\hat{x}} \cap \mathcal{G}) \leq 1$ for any critical family (otherwise, if $H, H' \in \mathcal{H}_{\hat{x}} \cap \mathcal{G}$ with $H \neq H'$, one could choose $W \in \mathcal{W}_H$ and $W' \in \mathcal{W}_{H'}$ with $W \cap W' = \emptyset$, contradicting the assumed consistency). By Lemma A.7, $\hat{x} \in M(X)$.

Conversely, Lemma A.7 implies that for any median point $\hat{x} \in M(X)$, the unanimity rule $F_{\hat{x}}$ satisfies the Intersection Property, hence is consistent by Proposition 3.5.

The last statement in Proposition 6.1 follows from Lemma A.2 above and the observation that $\{i\} \in \mathcal{W}_H$ whenever $H \supseteq \{\hat{x}, x_i^*\}$.

Proof of Proposition 6.2 The equivalence of (i) and (ii) follows at once from Proposition 6.1 using Theorem 1 and Fact 6.1. We now show that (i) implies (iii), and that (iii) implies (ii).

The implication (i) \Rightarrow (iii) is shown by contraposition; thus, assume that $H \equiv H^c$ for some $H \in \mathcal{H}$. By Fact 5.1, one has $\mathcal{W}_H = \mathcal{W}_{H^c}$ for any consistent voting by committees. But this contradicts the definition of a unanimity rule (whenever there are at least two voters).

To verify the implication (iii) \Rightarrow (ii), suppose that for all $H \in \mathcal{H}$, $H \not\equiv H^c$. Partition \mathcal{H} into $\mathcal{H}_1^-, \mathcal{H}_1^+, \mathcal{H}_2^-$ and \mathcal{H}_2^+ as in the proof of Theorem 5 above, where \mathcal{H}_2^- and \mathcal{H}_2^+ are determined according to Lemma A.6c). Then, any critical family \mathcal{G} can meet $\mathcal{H}_1^- \cup \mathcal{H}_2^-$ at most once. Indeed, by Lemma A.6a), $H \in \mathcal{G} \cap \mathcal{H}_1^-$ implies $\mathcal{G} \setminus \{H\} \subseteq \mathcal{H}_1^+$. Furthermore, if $\{H, H'\} \subseteq \mathcal{G} \cap \mathcal{H}_2^-$, one would obtain $H' \geq H^c$ which contradicts the construction of \mathcal{H}_2^- . But this implies that $\cap(\mathcal{H}_1^- \cup \mathcal{H}_2^-)$ is non-empty (otherwise it would contain a critical family), and by H3, it consists of a single element, say x . By Lemma A.7, $x \in M(X)$.

Proof of Theorem 6 Obviously, (i) implies (ii). Thus, it suffices to show that (ii) implies (iii), and that (iii) implies (i).

“(ii) \Rightarrow (iii)” We prove the claim by contraposition. Assume that $G \in \mathcal{H}$ is not quasi-unblocked. This means that $G \equiv G^c$, and there exists a critical family \mathcal{G} such that $(\mathcal{H}_{\equiv G} \cap \mathcal{G}) \supseteq \{H, H', H''\}$ for three distinct H, H', H'' . By Theorem 1, any strategy-proof $F : \mathcal{S}^n \rightarrow X$ takes the form of voting by committees. By Fact 5.1, $\mathcal{W}_H = \mathcal{W}_G$ for all $H \in \mathcal{H}_{\equiv G}$. By Lemma A.5, applied to the critical family $\mathcal{G} \supseteq \{H, H', H''\}$, there exists i , such that $\{i\} \in \mathcal{W}_H$ for all $H \in \mathcal{H}_{\equiv G}$. Hence, i is a dictator on $\mathcal{H}_{\equiv G}$, which proves the claim and the last statement in Theorem 6.

“(iii) \Rightarrow (i)” We will construct a consistent voting by quota rule, provided that (X, \mathcal{H}) is a quasi-quasi-median space. Partition \mathcal{H} as follows.

$$\begin{aligned} \mathcal{H}_0 &:= \{H \in \mathcal{H} : H \equiv H^c\}, \\ \mathcal{H}_1^+ &:= \{H \in \mathcal{H} : H > H^c\}, \\ \mathcal{H}_1^- &:= \{H \in \mathcal{H} : H^c > H\}, \\ \mathcal{H}_2 &:= \{H \in \mathcal{H} : \text{neither } H \geq H^c \text{ nor } H^c \geq H\}. \end{aligned}$$

Furthermore, partition \mathcal{H}_2 according to Lemma A.6c) into \mathcal{H}_2^- and \mathcal{H}_2^+ . Let n be odd, and define a voting by quota rule by setting

$$\begin{aligned} \mathcal{W}_H &= \{W : \#W > 1/2 \cdot n\} & \text{if } H \in \mathcal{H}_0, \\ \mathcal{W}_H &= 2^N \setminus \{\emptyset\} & \text{if } H \in \mathcal{H}_1^- \cup \mathcal{H}_2^-, \\ \mathcal{W}_H &= \{N\} & \text{if } H \in \mathcal{H}_1^+ \cup \mathcal{H}_2^+. \end{aligned}$$

Thus, the quotas correspond to $q_H = \frac{1}{2}$ for $H \in \mathcal{H}_0$ and $q_H = 1$ for $H \in \mathcal{H}_1^+ \cup \mathcal{H}_2^+$. Using the Intersection Property, we will show that this rule is consistent. Consider any critical family \mathcal{G} ; we distinguish three cases.

Case 1: $\mathcal{G} \cap (\mathcal{H}_1^- \cup \mathcal{H}_2^-) \neq \emptyset$. If $G \in \mathcal{G} \cap \mathcal{H}_1^-$, then by Lemma A.6a), $\mathcal{G} \setminus \{G\} \subseteq \mathcal{H}_1^+$, and the Intersection Property is clearly satisfied. Thus, suppose that there exists $H \in \mathcal{G} \cap \mathcal{H}_2^-$. By Lemma A.6b), we must have $\mathcal{G} \cap \mathcal{H}_0 = \emptyset$, and by Lemma A.6a), $\mathcal{G} \cap \mathcal{H}_1^- = \emptyset$. Hence, if there exists $H' \in \mathcal{G} \setminus \{H\}$ with $\mathcal{W}_{H'} \neq \{N\}$, we must have $H' \in \mathcal{H}_2^-$. But then $H \geq (H')^c$ which contradicts the construction of \mathcal{H}_2^- and \mathcal{H}_2^+

in Lemma A.6c). Thus, if $H \in \mathcal{G} \cap \mathcal{H}_2^-$, one has $\mathcal{W}_{H'} = \{N\}$ for any other element $H' \in \mathcal{G}$, in which case the Intersection Property is satisfied.

Case 2: $\mathcal{G} \cap \mathcal{H}_0 \neq \emptyset$. First, observe that $G_1 \equiv G_2$ whenever $\{G_1, G_2\} \subseteq \mathcal{G} \cap \mathcal{H}_0$. Indeed, $G_1 \equiv G_2$ follows at once from $G_1 \geq G_2^c$, $G_2 \geq G_1^c$, $G_1 \equiv G_1^c$ and $G_2 \equiv G_2^c$. Thus, since all basic properties are quasi-unblocked, \mathcal{G} can contain at most two elements of \mathcal{H}_0 . By Lemma A.6b), for any $H \in \mathcal{G} \setminus \mathcal{H}_0$ one has $\mathcal{W}_H = \{N\}$. Hence, the Intersection Property is also satisfied in Case 2.

Case 3: If \mathcal{G} does not meet \mathcal{H}_0 , \mathcal{H}_1^- and \mathcal{H}_2^- , then $\mathcal{G} \subseteq (\mathcal{H}_1^+ \cup \mathcal{H}_2^+)$, in which case the Intersection Property is trivially satisfied. This completes the proof of Theorem 6.

We now want to verify the remark after Theorem 6, that any consistent and anonymous rule *must* have the specified quotas whenever \mathcal{H}_0 is non-empty. To see this, consider $G \in \mathcal{H}_0$, i.e. $G \equiv G^c$. Since, by definition, $G \not\geq^0 G^c$, there must exist a different element $H \in \mathcal{H}$, such that $G \geq^0 H \geq^0 \dots \geq^0 G^c$. This implies at once that $\{H, H^c\} \subseteq \mathcal{H}_{\equiv G}$, and that there exists indeed a critical family that contains G and H^c . By Fact 5.1, any anonymous rule must thus be majority voting on \mathcal{H}_0 . Clearly, it must also give a quota of 1 to every basic property $H \in \mathcal{H} \setminus \mathcal{H}_0$ that is contained in a critical family which meets \mathcal{H}_0 twice. That such critical families necessarily exist can be verified as follows. As we just have seen, any $G \in \mathcal{H}_0$ is contained in a critical family \mathcal{G} that also contains another element $H \in \mathcal{H}_{\equiv G} \subseteq \mathcal{H}_0$. Since any basic property is quasi-unblocked, \mathcal{G} cannot contain other elements of \mathcal{H}_0 . However, it is also not possible that all critical families that meet \mathcal{H}_0 have cardinality two. Hence, there must exist a critical family that meets \mathcal{H}_0 twice but that also meets $\mathcal{H} \setminus \mathcal{H}_0$.

Proof of Fact 7.1 Clearly, if $\{i\} \in \mathcal{W}_H$, then voter i has veto power. Conversely, if no single individual ever forms a winning coalition, then any coalition of $n - 1$ voters is winning in any committee, by CS1; hence no voter has veto power.

Proof of Theorem 7 We prove the equivalence of (i) and (ii) as well as the equivalence of (ii) and (iii).

“(i) \Rightarrow (ii)” We show, by contraposition, that a violation of antisymmetry implies veto power. To show this we can restrict ourselves to voting by committees by Theorem 1. Hence, assume that for some $H \neq G$, $H \equiv G$. Then, there exist H_1, H_2, \dots, H_l such that $H_1 = H$, $H_l = H$, $H_j \geq^0 H_{j+1}$ and $H_k = G$ for some $1 < k < l$. This means that there exist critical families $\mathcal{G}_1, \dots, \mathcal{G}_{l-1}$ with $\mathcal{G}_j \supseteq \{H_j, H_{j+1}^c\}$ for $j = 1, \dots, l - 1$. At least one of these critical families must contain more than two elements, since otherwise $H_1 = H_k$, i.e. $H = G$. Without loss of generality, suppose $\mathcal{G}_1 \supseteq \{H_1, H_2^c, \hat{G}\}$ for some $\hat{G} \in \mathcal{H}$. We have $\mathcal{W}_{H_j} \subseteq \mathcal{W}_{H_{j+1}}$ for all $j = 1, \dots, l - 1$, and thus in fact $\mathcal{W}_{H_j} = \mathcal{W}_{H_{j'}}$ for all j, j' , by Fact 5.1. Applying Lemma A.5, we obtain $\{i\} \in \mathcal{W}_{\hat{G}^c}$, hence veto power.

“(ii) \Rightarrow (i)” Suppose \geq is antisymmetric; by a well-known result due to Szpilrajn, there exists a linear extension \geq^* of \geq on \mathcal{H} . Moreover, \geq^* can clearly be chosen to be complementation adapted. Set $\mathcal{H}_{>^*}^+ := \{H \in \mathcal{H} : H >^* H^c\}$ and $\mathcal{H}_{>^*}^- := \{H \in \mathcal{H} : H^c >^* H\}$. Furthermore, let $\rho(H) := \#\{H' : H' >^* H\}$, and define quotas as follows. For $H \in \mathcal{H}_{>^*}^+$, set $q_H = 1 - (1/2^{m-\rho(H)+1})$, where m is the number of issues (i.e. $2m = \#\mathcal{H}$), and for $H \in \mathcal{H}_{>^*}^-$, set $q_H = 1 - q_{H^c}$. We will show that the thus defined committee structure is consistent, using the Intersection Property.

First observe that a critical family \mathcal{G} can meet $\mathcal{H}_{>^*}^-$ at most once. Indeed, assume that $G_1, G_2 \in \mathcal{H}_{>^*}^- \cap \mathcal{G}$; this would imply, $G_1 >^* G_2^c$ and $G_2 >^* G_1^c$ (since $\{G_1, G_2\} \subseteq \mathcal{G}$), but also $G_2^c >^* G_2$ (since $G_2 \in \mathcal{H}_{>^*}^-$), hence $G_1 >^* G_1^c$, contradicting

the assumption that $G_1 \in \mathcal{H}_{>^*}^-$.

Now consider any critical family \mathcal{G} ; by the Intersection Property applied to voting by quota, it suffices to verify that $\sum_{H \in \mathcal{G}} q_H \geq \#\mathcal{G} - 1$ (cf. (3.4)). There are two cases to consider.

Case 1: $\mathcal{G} \cap \mathcal{H}_{>^*}^- = \emptyset$. In this case,

$$\sum_{H \in \mathcal{G}} q_H = \#\mathcal{G} - \sum_{H \in \mathcal{G}} \left(\frac{1}{2}\right)^{m-\rho(H)+1}.$$

But $\sum_{H \in \mathcal{G}} \left(\frac{1}{2}\right)^{m-\rho(H)+1} \leq \sum_{H \in \mathcal{H}_{>^*}^+} \left(\frac{1}{2}\right)^{m-\rho(H)+1} < \frac{1}{2}$, since $\rho(H) \leq m - 1$ for all $H \in \mathcal{H}_{>^*}^+$ due to the complementation adaptedness; hence (3.4) is satisfied.

Case 2: $\mathcal{G} \cap \mathcal{H}_{>^*}^- = \{H_0\}$. We have,

$$\sum_{H \in \mathcal{G}} (1 - q_H) = \sum_{H \in \mathcal{G} \setminus \{H_0\}} \left(\frac{1}{2}\right)^{m-\rho(H)+1} + \left(1 - \left(\frac{1}{2}\right)^{m-\rho(H_0^c)+1}\right).$$

Therefore, for (3.4) to be satisfied it is sufficient that

$$\sum_{H \in \mathcal{G} \setminus \{H_0\}} \left(\frac{1}{2}\right)^{m-\rho(H)+1} \leq \left(\frac{1}{2}\right)^{m-\rho(H_0^c)+1}. \quad (\text{A.2})$$

This can be verified as follows. Since $H_0 \in \mathcal{G}$, we have $H >^* H_0^c$ for all $H \in \mathcal{G} \setminus \{H_0\}$. This implies $\rho(H_0^c) > \max_{H \in \mathcal{G} \setminus \{H_0\}} \rho(H)$, and hence (A.2).

Observe that, since the no veto power rule just constructed is anonymous, we have in fact proved that antisymmetry of \geq is equivalent to *anonymous* no veto power.

For the proof of the equivalence of (ii) and (iii), we need the following lemma.

Lemma A.8 *Consider any family $\mathcal{F} \subseteq \mathcal{H}$; then, \mathcal{G} is a critical family of the projected space $(X/\mathcal{F}, \mathcal{F})$ if and only if \mathcal{G} is critical in (X, \mathcal{H}) and $\mathcal{G} \subseteq \mathcal{F}$.*

Proof of Lemma A.8 Obviously, if \mathcal{G} is critical in $(X/\mathcal{F}, \mathcal{F})$, then $\mathcal{G} \subseteq \mathcal{F}$ and \mathcal{G} is critical in (X, \mathcal{H}) . Conversely, let $\mathcal{G} \subseteq \mathcal{F}$ be critical in (X, \mathcal{H}) . Since no element in X possesses all properties in \mathcal{G} , there can also not exist an element in X/\mathcal{F} that jointly possesses these properties. On the other hand, if $x \in X$ possesses all properties of a proper subset of \mathcal{G} , then the projection of x to X/\mathcal{F} possesses these properties as well.

Proof of Theorem 7 (cont.) “(iii) \Rightarrow (ii)” We show, by contraposition, that if \geq is not antisymmetric, then (X, \mathcal{H}) is not a cohesive quasi-median space. Thus, assume that there exist $H_1, \dots, H_k \in \mathcal{H}$ and critical families $\mathcal{G}_1, \dots, \mathcal{G}_k$ such that $\mathcal{G}_j \supseteq \{H_j, H_{j+1}^c\}$ for $j < k$ and $\mathcal{G}_k \supseteq \{H_k, H_1^c\}$. Let $\mathcal{H} = \{H_1, \dots, H_m\} \cup \{H_1^c, \dots, H_m^c\}$, and denote by $\tilde{\mathcal{H}} := \{H_1, \dots, H_k\} \cup \{H_1^c, \dots, H_k^c\}$. As is easily verified, \mathcal{G}_j and H_j can be chosen such that $\mathcal{G}_j \cap \tilde{\mathcal{H}} = \{H_j, H_{j+1}^c\}$ and $\mathcal{G}_k \cap \tilde{\mathcal{H}} = \{H_k, H_1^c\}$.

The set $\tilde{\mathcal{G}} := (\cup_{j=1}^k \mathcal{G}_j) \setminus \tilde{\mathcal{H}}$ cannot be empty, since otherwise $H_1 \subseteq H_2 \subseteq \dots \subseteq H_k \subseteq H_1$, hence all H_j would be identical. Moreover, if for some $H \in \mathcal{H}$, $\tilde{\mathcal{G}} \supseteq \{H, H^c\}$, one would obtain $H \equiv H^c$; in that case (X, \mathcal{H}) would not even be a quasi-median space by Proposition 6.2. Hence, assume $\tilde{\mathcal{G}} = \{H_{k+1}^c, \dots, H_l^c\}$ for some $l > k$. By Lemma A.8, we can assume without loss of generality that $l = m$; indeed, otherwise consider the projected space $(X/\mathcal{F}, \mathcal{F})$ induced by the family $\mathcal{F} = \{H_1, \dots, H_l\} \cup \{H_1^c, \dots, H_l^c\}$.

Take any $x \in M(X)$. If $x \in H_1$, one must also have $x \in H_2$, since otherwise $x \notin M(X)$ by Lemma A.7. By induction, one thus obtains $x \in H_j$ for all $j \in \{2, \dots, m\}$. On the other hand, if $x \in H_1^c$, then by the same argument using Lemma A.7, $x \in H_j^c$ for $j \in \{2, \dots, k\}$ and $x \in H_j$ for $j \in \{k+1, \dots, m\}$. In other words, if $\#M(X) \geq 2$, then necessarily $M(X) = \{x, x'\}$ where $\{x\} = H_1 \cap H_2 \cap \dots \cap H_m$ and $\{x'\} = H_1^c \cap H_2^c \cap \dots \cap H_k^c \cap H_{k+1} \cap \dots \cap H_m$. But in this case, $M(X)$ is clearly not connected, i.e. (X, \mathcal{H}) is not a cohesive quasi-median space.

“(ii) \Rightarrow (iii)” Let \geq be antisymmetric. By Proposition 6.2, (X, \mathcal{H}) is a quasi-median space, i.e. $M(X)$ is non-empty. First, we show that $\#M(X) \geq 2$. Take any $x \in M(X)$ and let $\mathcal{H}_x = \{H_1, \dots, H_m\}$. Then, for no $j \in \{1, \dots, m\}$, $H_j \geq H_j^c$; indeed, otherwise $H_j \geq^0 G_1 \geq^0 \dots \geq^0 G_l \geq^0 H_j^c$ for some G_1, \dots, G_l . Using Lemma A.7, this would imply $x \in G_1$; by induction, one would obtain $x \in G_j$, for all $j = 1, \dots, l$, and $x \in H_j^c$, which is obviously not possible. We show that, for some k , also not $(H_k^c \geq H_k)$. Assume, by way of contradiction that $H_j^c \geq H_j$ for all j , and let H_l^c be \geq -minimal among $\{H_1^c, \dots, H_m^c\}$. Since $H_l^c \geq H_l$ but, by definition, $H_l^c \not\geq^0 H_l$, we must have either (a) $H_l^c \geq H_j^c \geq H_l$, or (b) $H_l^c \geq H_j \geq H_l$, for some $j \neq l$. In case (a), $H_l^c \equiv H_j^c$ by the minimality of H_l^c ; this contradicts the antisymmetry of \geq . In case (b), one has $H_l^c \geq H_j^c$ by the complementation adaptedness, hence again $H_l^c \equiv H_j^c$ by minimality of H_l^c , contradicting the antisymmetry of \geq . This shows that, for some k , neither $H_k \geq H_k^c$ nor $H_k^c \geq H_k$. Consider the partition of \mathcal{H} into \mathcal{H}_1^+ , \mathcal{H}_1^- and \mathcal{H}_2 as in the proofs of Theorem 5 and 6 above (note that $\mathcal{H}_0 = \emptyset$ here, since $M(X) \neq \emptyset$). We have just shown that $\{H_k, H_k^c\} \subseteq \mathcal{H}_2$. Partition \mathcal{H}_2 into \mathcal{H}_2^- and \mathcal{H}_2^+ according to Lemma A.6c) such that $H_k \in \mathcal{H}_2^-$. Any critical family can meet $\mathcal{H}_1^- \cup \mathcal{H}_2^-$ at most once by Lemma A.6a) and A.6c). Thus, $\cap(\mathcal{H}_1^- \cup \mathcal{H}_2^-)$ is non-empty and contains a single element, say x . By Lemma A.7, $x \in M(X)$, and by construction $x \in H_k$. Analogously, we can partition \mathcal{H}_2 such that $H_k^c \in \mathcal{H}_2^-$ and obtain a median point in H_k^c . Hence, $\#M(X) \geq 2$.

Next, we show that $M(X)$ is connected. Consider two elements x and y in $M(X)$, where $\mathcal{H}_x = \{H_1, \dots, H_l, H_{l+1}, \dots, H_m\}$ and $\mathcal{H}_y = \{H_1^c, \dots, H_l^c, H_{l+1}, \dots, H_m\}$. We will show that there is a sequence of immediate neighbours in $M(X)$ that connects x and y . If $l = 1$ there is nothing to prove, hence assume $l \geq 2$. We prove that there exists an element in $M(X)$ that is one step closer to x than y . Let $\mathcal{H}^1 = (\mathcal{H}_y \setminus \{H_{j_1}^c\}) \cup \{H_{j_1}\}$ for some $j_1 \in \{1, \dots, l\}$. If $\cap \mathcal{H}^1 = \{y_1\}$ with $y_1 \in M(X)$, we are done. If not, \mathcal{H}^1 must meet some critical family \mathcal{G} at least twice by Lemma A.7; moreover, since $y \in M(X)$, we must have $H_{j_1} \in \mathcal{G}$. Since $x \in M(X)$, it is not possible that $\mathcal{G} \setminus \{H_{j_1}\} \subseteq \{H_{l+1}, \dots, H_m\}$. Hence $H_{j_1} \geq H_{j_2}$ for some $j_2 \in \{1, \dots, l\} \setminus \{j_1\}$. Now consider $\mathcal{H}^2 = (\mathcal{H}_y \setminus \{H_{j_2}^c\}) \cup \{H_{j_2}\}$. If $\cap \mathcal{H}^2 = \{y_2\}$ with $y_2 \in M(X)$, we are again done. If not, we must have $H_{j_2} \geq H_{j_3}$ for some $j_3 \in \{1, \dots, l\} \setminus \{j_2\}$ as before, and by antisymmetry in fact, $j_3 \in \{1, \dots, l\} \setminus \{j_1, j_2\}$. By induction, we thus can find an immediate neighbour y_k of y such that $y_k \in M(X) \cap H_k$ for some $k \in \{1, \dots, l\}$. Repeating this procedure, a sequence of immediate neighbours in $M(X)$ connecting y and x can thus be constructed.

The proof is completed by noting that due to Lemma A.8, antisymmetry of \geq on (X, \mathcal{H}) implies antisymmetry of the corresponding entailment relation on any projected space $(X/\mathcal{F}, \mathcal{F})$.

References

- [1] ASWAL, N., S. CHATTERJI and A. SEN (2002), Dictatorial Domains, *Economic Theory*, forthcoming.
- [2] BANDELT, H.-J. and J. HEDLIKOVÁ (1983), Median Algebras, *Discrete Mathematics* **45**, 1-30.
- [3] BARBERÁ, S., F. GUL and E. STACCHETTI (1993), Generalized Median Voter Schemes and Committees, *Journal of Economic Theory* **61**, 262-289.
- [4] BARBERÁ, S., J. MASSÒ and A. NEME (1997), Voting under Constraints, *Journal of Economic Theory* **76**, 298-321.
- [5] BARBERÁ, S., J. MASSÒ and A. NEME (2001), Voting by Committees under Constraints, *mimeo*.
- [6] BARBERÁ, S., H. SONNENSCHNEIN and L. ZHOU (1991), Voting by Committees, *Econometrica* **59**, 595-609.
- [7] BENOIT, J.-P. (2000), The Gibbard-Satterthwaite Theorem: A Simple Proof, *Economics Letters* **69**, 319-322.
- [8] BOGOMOLNAIA, A. (1999), A Characterization of Median Rules, *mimeo*.
- [9] BORDER, K. and J. JORDAN (1983), Straightforward Elections, Unanimity and Phantom Voters, *Review of Economic Studies* **50**, 153-170.
- [10] DEMANGE, G. (1982), Single Peaked Orders on a Tree, *Mathematical Social Sciences* **3**, 389-396.
- [11] LE BRETON, M. and A. SEN (1999), Separable Preferences, Strategyproofness, and Decomposability, *Econometrica* **67**, 605-628.
- [12] MOULIN, H. (1980), On Strategy-Proofness and Single-Peakedness, *Public Choice* **35**, 437-455.
- [13] NEHRING, K. (1999), Diversity and the Geometry of Similarity, *mimeo*, available at <http://www.econ.ucdavis.edu/faculty/nehring/papers.html>
- [14] NEHRING, K. and C. PUPPE (2002a), When are Strategy-Proof Voting Mechanisms Efficient?, *in preparation*.
- [15] NEHRING, K. and C. PUPPE (2002b), Voting by Quota Outside Median Spaces, *in preparation*.
- [16] RENY, P. (2001), Arrow's Theorem and the Gibbard-Satterthwaite Theorem: A Unified Approach, *Economics Letters* **70**, 99-105.
- [17] SEN, A. (2001), Another Direct Proof of the Gibbard-Satterthwaite Theorem, *Economics Letters* **70**, 381-385.
- [18] VAN DE VEL, M. (1993), *Theory of Convex Structures*, North Holland, Amsterdam.